

# Typical Section (NOT TO SCALE)

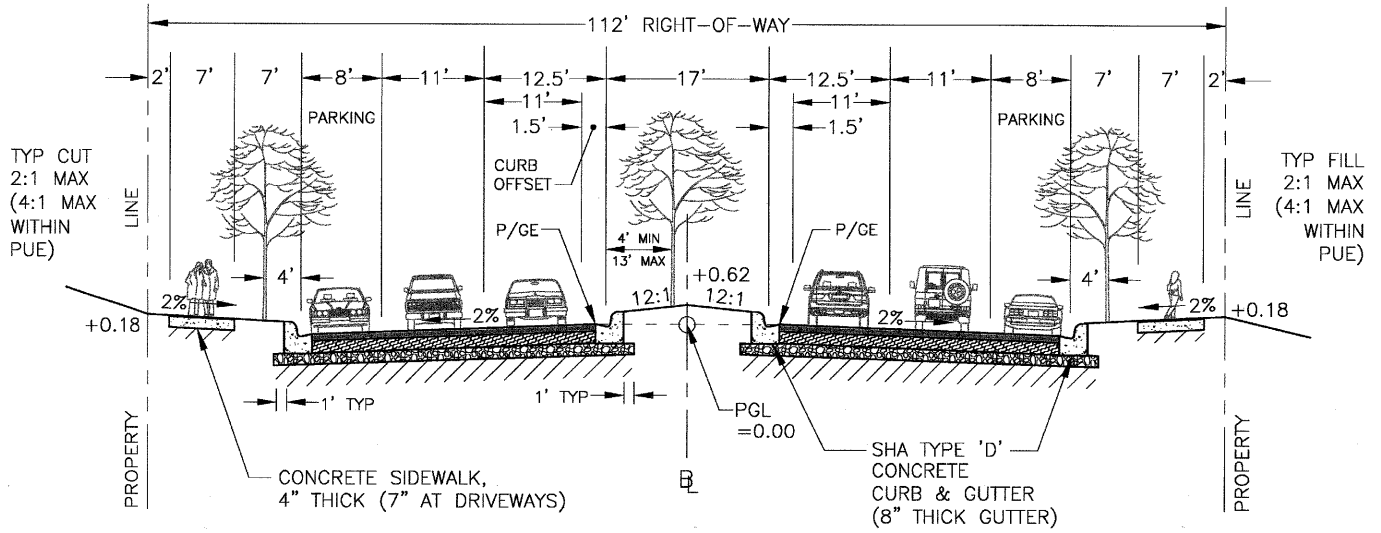

## Paving Detail

	3" BITUMINOUS CONCRETE SURFACE (TWO EQUAL LAYERS)
	5" BITUMINOUS CONCRETE BASE
	8" GRADED AGGREGATE BASE (TWO EQUAL LAYERS)
	APPROVED SUBGRADE

## Design Data

GEOMETRIC DESIGN SHALL CONFORM TO MOST RECENT AASHTO "GREEN BOOK" METHODS.

TARGET SPEED (MPH)	SUPERELEVATION DISTRIBUTION	MAX GRADE
25*	NONE (-2% MAX)	8%
30	NONE (-2% MAX)	8%
35**	NONE (-2% MAX)	8%

\* MIN ALLOWABLE  $\Delta$  RADIUS = 300'

\*\* SUBURBAN OR RURAL ONLY

## General Notes

- LATEST EDITION OF THE MARYLAND STATE HIGHWAY ADMINISTRATION SPECIFICATIONS SHALL APPLY FOR MATERIALS AND METHODS OF CONSTRUCTION.
- PUBLIC UTILITY EASEMENTS (PUEs) ARE SUBJECT TO "DECLARATIONS OF TERMS AND PROVISIONS OF PUBLIC UTILITY EASEMENTS" RECORDED AS LIBER 3834, FOLIO 457 IN THE LAND RECORDS OF MONTGOMERY COUNTY.
- STANDARD ELEVATION AT PROPERTY LINE, RELATIVE TO PGL, SHALL NOT VARY AT DRIVEWAYS.
- PAVING DETAIL DEPICTS THE MINIMUM REQUIRED SECTION. IF SUFFICIENT SUBGRADE SUPPORT IS NOT ASSURED, AN ENGINEERED PAVING DESIGN USING SHA METHODOLOGY WILL BE REQUIRED.
- NOTE THAT WITHIN A GIVEN CONTEXT, THIS STANDARD MAY NEED TO BE MODIFIED TO PROVIDE ADDITIONAL REQUIRED FEATURES SUCH AS MASTER PLANNED BIKEWAYS, AUXILIARY LANES AT INTERSECTIONS, OR STORMWATER MANAGEMENT FACILITIES. ADDITIONAL RIGHT-OF-WAY MAY BE NECESSARY TO ACCOMMODATE SUCH FEATURES.
- SELECTION OF APPROPRIATE TARGET SPEED (EQUAL OR SLIGHTLY LESS THAN DESIGN SPEED) IS SUBJECT TO COUNTY REVIEW AND APPROVAL. APPROVED TARGET AND DESIGN SPEEDS MUST APPEAR ON CONSTRUCTION DRAWINGS.
- THE 2% CROSS-SLOPE RATE SHOWN IS TO BE USED FOR A MAXIMUM WIDTH OF TWO TRAFFIC LANES STARTING AT THE HIGH POINT OF THE PAVING SECTION. IF ADDITIONAL LANES ARE NECESSARY BELOW, THEY MUST BE CROSS-SLOPED AT A 4% MINIMUM RATE TO ENSURE ADEQUATE DRAINAGE.
- ALL UNPAVED AREAS WITHIN THE LIMITS OF DISTURBANCE SHALL BE STABILIZED WITH ESTABLISHED GRASS TURF OR APPROVED LANDSCAPING.
- STREET TREES OF APPROVED TYPE, SIZE AND SPACING SHALL BE PLANTED AT LOCATIONS SHOWN.

STANDARD DEVELOPED AND IMPLEMENTED IN CONFORMANCE WITH COUNCIL RESOLUTION 16-809 ADOPTED DEC. 9, 2008

DIRECTOR, DEPARTMENT OF TRANSPORTATION  
  
 CHIEF, DIVISION OF TRANSPORTATION ENGINEERING

25 JUN 12  
 DATE

6/21/2012  
 DATE

MONTGOMERY COUNTY  
 DEPARTMENT OF TRANSPORTATION

DIVIDED BUSINESS DISTRICT STREET  
 4 LANES WITH PARKING

STANDARD NO. MC-2005.04