

Typical Section (NOT TO SCALE)

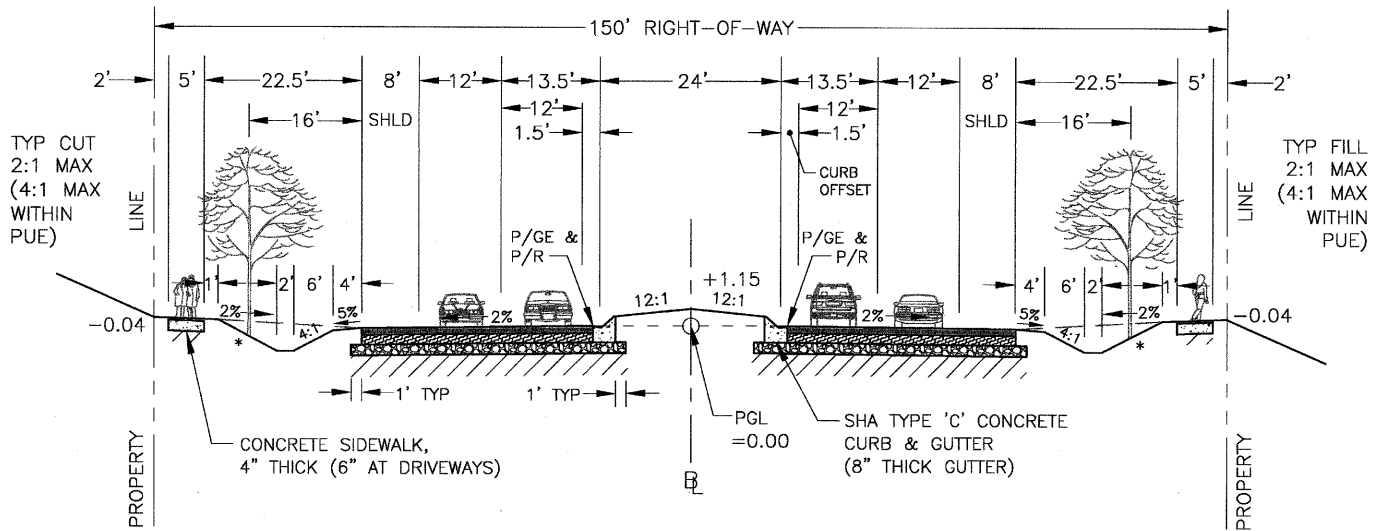

*BACKSLOPES ARE APPROXIMATELY 4.5:1

Paving Detail

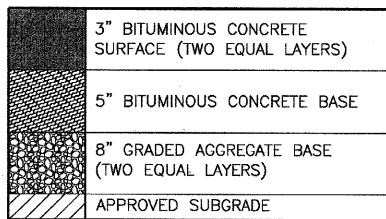

Design Data

GEOMETRIC DESIGN SHALL CONFORM TO MOST RECENT AASHTO "GREEN BOOK" METHODS.

TARGET SPEED (MPH)	SUPERELEVATION DISTRIBUTION	MAX GRADE
50	AASHTO METHOD 5 (6% MAX)	5%
55	AASHTO METHOD 5 (6% MAX)	4 1/2%

General Notes

1. LATEST EDITION OF THE MARYLAND STATE HIGHWAY ADMINISTRATION SPECIFICATIONS SHALL APPLY FOR MATERIALS AND METHODS OF CONSTRUCTION.
2. PUBLIC UTILITY EASEMENTS (PUEs) ARE SUBJECT TO "DECLARATIONS OF TERMS AND PROVISIONS OF PUBLIC UTILITY EASEMENTS" RECORDED AS LIBER 3834, FOLIO 457 IN THE LAND RECORDS OF MONTGOMERY COUNTY.
3. DRIVEWAY ACCESS IS NOT PERMITTED ON RURAL MAJOR HIGHWAYS.
4. PAVING DETAIL DEPICTS THE MINIMUM REQUIRED SECTION. IF SUFFICIENT SUBGRADE SUPPORT IS NOT ASSURED, AN ENGINEERED PAVING DESIGN USING SHA METHODOLOGY WILL BE REQUIRED.
5. NOTE THAT WITHIN A GIVEN CONTEXT, THIS STANDARD MAY NEED TO BE MODIFIED TO PROVIDE ADDITIONAL REQUIRED FEATURES SUCH AS MASTER PLANNED BIKEWAYS, AUXILIARY LANES AT INTERSECTIONS, OR STORMWATER MANAGEMENT FACILITIES. ADDITIONAL RIGHT-OF-WAY MAY BE NECESSARY TO ACCOMMODATE SUCH FEATURES.
6. SELECTION OF APPROPRIATE TARGET SPEED (EQUAL OR SLIGHTLY LESS THAN DESIGN SPEED) IS SUBJECT TO COUNTY REVIEW AND APPROVAL. APPROVED TARGET AND DESIGN SPEEDS MUST APPEAR ON CONSTRUCTION DRAWINGS.
7. ALL UNPAVED AREAS WITHIN THE LIMITS OF DISTURBANCE SHALL BE STABILIZED WITH ESTABLISHED GRASS TURF OR APPROVED LANDSCAPING.
8. STREET TREES OF APPROVED TYPE, SIZE AND SPACING SHALL BE PLANTED AT LOCATIONS SHOWN.

STANDARD DEVELOPED AND IMPLEMENTED IN CONFORMANCE WITH COUNCIL RESOLUTION 16-809 ADOPTED DEC. 9, 2008

Arthur Haly
 DIRECTOR, DEPARTMENT OF TRANSPORTATION
 DATE: 25 JUN 12

Ben S. Johnson
 CHIEF, DIVISION OF TRANSPORTATION ENGINEERING
 DATE: 6/21/2012

MONTGOMERY COUNTY
 DEPARTMENT OF TRANSPORTATION

RURAL MAJOR HIGHWAY
 OPEN SECTION: 4 LANES
 SIDEWALK ON BOTH SIDES - 50 & 55 MPH

STANDARD NO. MC-2008.05D