

Typical Section (NOT TO SCALE)

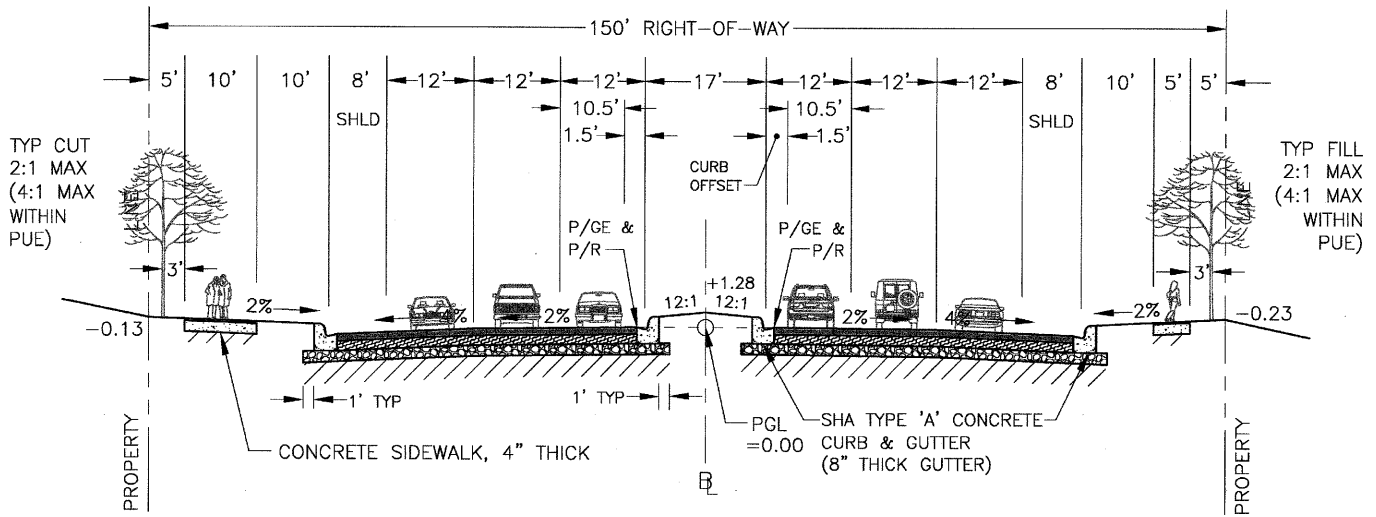

Paving Detail

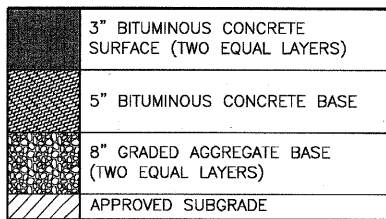

Design Data

GEOMETRIC DESIGN SHALL CONFORM TO MOST RECENT AASHTO "GREEN BOOK" METHODS.

TARGET SPEED (MPH)	SUPERELEVATION DISTRIBUTION	MAX GRADE
45	AASHTO METHOD 5 (4% MAX)	5 1/2%
50	AASHTO METHOD 5 (4% MAX)	5%

General Notes

1. LATEST EDITION OF THE MARYLAND STATE HIGHWAY ADMINISTRATION SPECIFICATIONS SHALL APPLY FOR MATERIALS AND METHODS OF CONSTRUCTION.
2. PUBLIC UTILITY EASEMENTS (PUEs) ARE SUBJECT TO "DECLARATIONS OF TERMS AND PROVISIONS OF PUBLIC UTILITY EASEMENTS" RECORDED AS LIBER 3834, FOLIO 457 IN THE LAND RECORDS OF MONTGOMERY COUNTY.
3. DRIVEWAY ACCESS IS NOT PERMITTED ON CONTROLLED MAJOR HIGHWAYS.
4. PAVING DETAIL DEPICTS THE MINIMUM REQUIRED SECTION. IF SUFFICIENT SUBGRADE SUPPORT IS NOT ASSURED, AN ENGINEERED PAVING DESIGN USING SHA METHODOLOGY WILL BE REQUIRED.
5. NOTE THAT WITHIN A GIVEN CONTEXT, THIS STANDARD MAY NEED TO BE MODIFIED TO PROVIDE ADDITIONAL REQUIRED FEATURES SUCH AS MASTER PLANNED BIKEWAYS, AUXILIARY LANES AT INTERSECTIONS, OR STORMWATER MANAGEMENT FACILITIES. ADDITIONAL RIGHT-OF-WAY MAY BE NECESSARY TO ACCOMMODATE SUCH FEATURES.
6. NOTE THAT ROADWAY SECTION IS NOT SYMMETRICAL RELATIVE TO BASELINE. ACTUAL ORIENTATION OF LEFT AND RIGHT IS SUBJECT TO COUNTRY REVIEW AND APPROVAL.
7. SELECTION OF APPROPRIATE TARGET SPEED (EQUAL OR SLIGHTLY LESS THAN DESIGN SPEED) IS SUBJECT TO COUNTY REVIEW AND APPROVAL. APPROVED TARGET AND DESIGN SPEEDS MUST APPEAR ON CONSTRUCTION DRAWINGS.
8. ALL UNPAVED AREAS WITHIN THE LIMITS OF DISTURBANCE SHALL BE STABILIZED WITH ESTABLISHED GRASS TURF OR APPROVED LANDSCAPING.
9. STREET TREES OF APPROVED TYPE, SIZE AND SPACING SHALL BE PLANTED AT LOCATIONS SHOWN.

STANDARD DEVELOPED AND IMPLEMENTED IN CONFORMANCE WITH COUNCIL RESOLUTION 16-809 ADOPTED DEC. 9, 2008

Keith Halpe
 DIRECTOR, DEPARTMENT OF TRANSPORTATION

Ben S. Pluh
 CHIEF, DIVISION OF TRANSPORTATION ENGINEERING

25JW112
 DATE

6/21/2012
 DATE

MONTGOMERY COUNTY
 DEPARTMENT OF TRANSPORTATION

URBAN CONTROLLED MAJOR HIGHWAY
 6 LANES
 45 & 50 MPH

STANDARD NO. MC-2008.08