

- ① TWO - 1 1/2" BITUMINOUS CONCRETE SURFACE COURSE
- ② BITUMINOUS CONCRETE BASE COURSE SEE NOTE 3.
- ③ SUBBASE MATERIAL SEE NOTE 3

ARTERIAL ROADWAY
(OR HIGHER CLASSIFICATION)

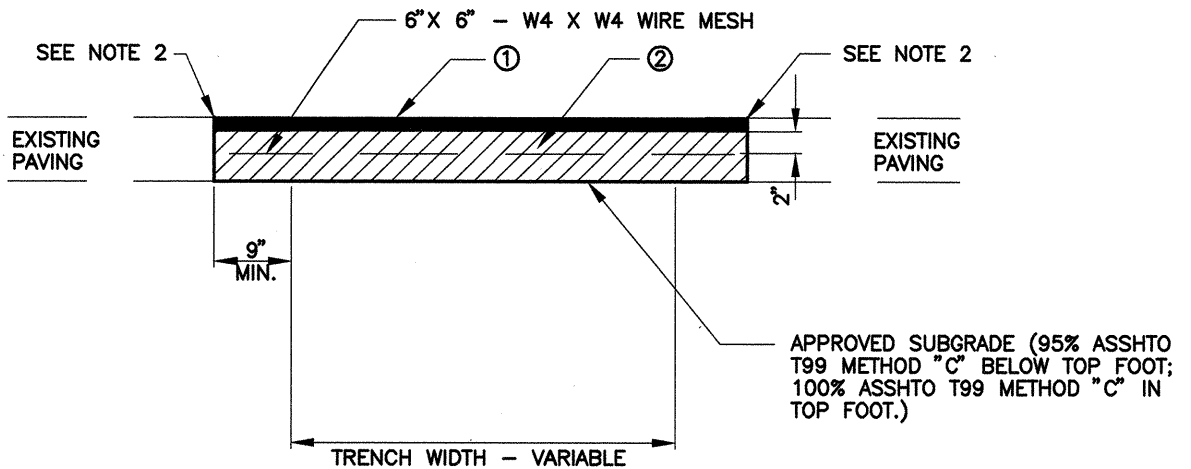

CONCRETE OPTION

- ① 1 1/2" BITUMINOUS CONCRETE SURFACE COURSE
- ② 6" MINIMUM CONCRETE PATCH

PRIMARY ROADWAY
(OR LOWER CLASSIFICATION)

BITUMINOUS OPTION

- ① 1 1/2" BITUMINOUS CONCRETE SURFACE COURSE
- ② BITUMINOUS CONCRETE BASE COURSE SEE NOTE 3

GENERAL NOTES

1. REFER TO M.C.D.O.T. UTILITY PATCH SPECIFICATIONS FOR MATERIALS AND METHODS OF CONSTRUCTION.
2. EXISTING PAVEMENT MUST BE SAW CUT FULL DEPTH PRIOR TO EXCAVATION.
3. BASE COURSE AND SUBBASE MATERIAL SHALL CONFORM TO APPROPRIATE ROADWAY CLASSIFICATION DESIGN STANDARD OR MATCH EXISTING CONDITION, WHICHEVER IS GREATER.

PANDITSTD\MCS0102 6-24-94 111210 am EST

APPROVED JAN 5/95
DATE

[Signature]
DIRECTOR, DEPT. OF TRANS.
[Signature]
CHIEF, DIV. OF ENG. SERVICES

REVISED

MONTGOMERY COUNTY
DEPARTMENT OF TRANSPORTATION

UTILITY PATCH
IN FLEXIBLE PAVEMENT

STANDARD NO. MC-801.02