



---

## Montgomery County Government

---

# Drainage Design Criteria

---

## Department of Transportation

---

November 2013 • Rockville, Maryland

**Revised Final**  
June 10, 2014

# TABLE OF CONTENTS

<b>1</b>	<b>INTRODUCTION.....</b>	<b>1</b>
1.1	PURPOSE OF THE DRAINAGE DESIGN CRITERIA .....	1
1.2	LAWS ORDINANCES AND POLICIES .....	1
1.3	RIGHT-OF-WAY, EASEMENTS, OWNERSHIP, AND MAINTENANCE .....	3
1.3.1	<i>General Policy</i> .....	3
1.3.2	<i>Storm Drain Easements</i> .....	5
1.3.3	<i>Channels and Outlets</i> .....	6
1.3.4	<i>Maintenance &amp; Access</i> .....	6
1.3.5	<i>Connection to existing Storm Drain Systems</i> .....	7
<b>2</b>	<b>SUBMISSION AND APPROVAL PROCEDURES .....</b>	<b>8</b>
2.1	DRAINAGE STUDY .....	8
2.1.1	<i>General Information</i> .....	8
2.1.2	<i>Drainage Area Map</i> .....	9
2.1.3	<i>Hydrologic Calculations</i> .....	10
2.1.4	<i>Hydraulic Calculations</i> .....	10
2.1.5	<i>Miscellaneous Calculations</i> .....	11
2.2	PLAN PERMIT SUBMITTALS .....	11
2.2.1	<i>Permit Submittal requirements</i> .....	11
2.2.2	<i>Easements Storm Drain Plans</i> .....	11
2.2.3	<i>Storm Drain Profiles</i> .....	13
2.2.4	<i>Plan Notes</i> .....	13
2.3	DISCREPANCIES AND REVISIONS .....	14
2.3.1	<i>Plan Discrepancies</i> .....	14
2.3.2	<i>Plan Revisions</i> .....	14
2.4	UTILITIES .....	14
2.4.1	<i>General</i> .....	14
2.4.2	<i>Utility Identification</i> .....	15
2.4.3	<i>Utility Verification Plans &amp; Coordination</i> .....	15
2.4.4	<i>Clearance with Other Utilities</i> .....	15
<b>3</b>	<b>HYDROLOGIC ANALYSIS.....</b>	<b>16</b>
3.1	GENERAL.....	16
3.2	TIME OF CONCENTRATION .....	17
3.2.1	<i>Rational Method</i> .....	17
3.2.2	<i>NRCS (SCS) TR-55</i> .....	18
	PEAK DISCHARGE COMPUTATIONS.....	21
3.2.3	<i>Rational Method</i> .....	21
3.2.4	<i>NRCS Method</i> .....	26
3.3	HYDROGRAPH METHODS .....	31
3.3.1	<i>TR-55 Method</i> .....	31
3.3.2	<i>TR-20 Method</i> .....	31
3.4	GIS HYDRO 2000 .....	32
3.5	CONCURRENT FLOOD ANALYSIS .....	32
3.6	BANKFULL DISCHARGE ESTIMATES .....	33
<b>4</b>	<b>HYDRAULIC DESIGN.....</b>	<b>34</b>
4.1	GENERAL.....	34
4.1.1	<i>On-site and Off-site Considerations</i> .....	34
4.2	PAVEMENT DRAINAGE .....	35
4.2.1	<i>Street Capacity (Spread)</i> .....	35

4.2.2	<i>Inlet Spacing, Size and Capacity</i> .....	36
4.2.3	<i>Grates</i> .....	39
4.2.4	<i>Manholes, Inlets, and Field Connections</i> .....	40
4.3	STORM DRAIN DESIGN.....	41
4.3.1	<i>Determination of Conveyance Size</i> .....	41
4.3.2	<i>Hydraulic Gradient</i> .....	43
4.3.3	<i>Pipe Design Requirements</i> .....	47
4.4	BRIDGES AND CULVERTS.....	49
4.4.1	<i>General Considerations</i> .....	49
4.4.2	<i>Classification and Review</i> .....	50
4.4.3	<i>Design Considerations</i> .....	50
4.4.4	<i>Site Inventory</i> .....	54
4.5	ENTRANCES AND EXITS IN STORM DRAIN SYSTEMS.....	55
4.5.1	<i>Storm Drain System Entrances and Stabilization</i> .....	55
4.5.2	<i>Outlet Structures</i> .....	56
4.5.3	<i>Outlet Velocity</i> .....	57
4.5.4	<i>Types of Inlet and Outlet Stabilization for All Structures</i> .....	57
4.6	OPEN CHANNELS.....	59
4.6.1	<i>Design Requirements</i> .....	59
4.6.2	<i>Design Channels</i> .....	59
4.6.3	<i>Natural Channels</i> .....	60
4.6.4	<i>Roadside Ditches</i> .....	61
4.7	RIPRAP.....	63
4.7.1	<i>Riprap Outfall Protection</i> .....	63
4.7.2	<i>Riprap Classification</i> .....	65
4.7.3	<i>Riprap Bank Protection</i> .....	65
4.8	RESIDENTIAL LOT DRAINAGE REQUIREMENTS.....	66
4.8.1	<i>Drainage Swales and Surface Drainage Easements</i> .....	66
<b>5</b>	<b>MISCELLANEOUS DRAINAGE</b> .....	<b>67</b>
5.1	SUMP PUMP DISCHARGES.....	67
5.1.1	<i>Types of sump pump discharges allowed:</i> .....	67
5.1.2	<i>Alternative Discharges of sump pumps</i> .....	67
5.2	DRIVEWAY CULVERTS.....	67
<b>6</b>	<b>COMPUTER SOFTWARE</b> .....	<b>69</b>
6.1	FEDERAL AND STATE APPROVED SOFTWARE.....	69
6.1.1	<i>Hydrologic Software:</i> .....	69
6.1.2	<i>Storm Drain Software:</i> .....	69
6.1.3	<i>Bridge and Culvert Software:</i> .....	69
6.3	THIRD PARTY SOFTWARE.....	70
6.3.1	<i>Hydrologic Software:</i> .....	<b>Error! Bookmark not defined.</b>
6.3.2	<i>Storm Drain Software:</i> .....	<b>Error! Bookmark not defined.</b>
6.3.3	<i>Bridge and Culvert Software:</i> .....	<b>Error! Bookmark not defined.</b>

## Table of Tables

Table 1-1 - Minimum Right-of-Way .....	5
Table 2-1 – Pipe and Culvert Material Abbreviations .....	13
Table 3-1 - Context Sensitive Design Classification .....	16
Table 3-2 – Hydrologic Methods by Drainage Area.....	17
Table 3-3 – Small Drainage Area Time of Concentration.....	17
Table 3-4 – Common Overland Flow Roughness Coefficients (n) .....	19
Table 3-5 – Runoff Coefficients .....	23
Table 3-6 – Correction Factor .....	25
Table 3-7 – Intensity-.Duration - Frequency (IDF) Data .....	25
Table 3-8 – NRCS Curve Numbers .....	28
Table 3-9 – Coefficients for 24-hour Rainfall.....	29
Table 3-10 – Adjustment Factor (Fp) for pond and Swamp Areas .....	29
Table 3-11 – Storm Duration (24-hr Rainfall) .....	<b>Error! Bookmark not defined.</b>
Table 3-12 – Concurrent Flood Ratios .....	32
Table 4-1 – Site Considerations .....	34
Table 4-2 – MCDOT & MSHA Gutter Widths and Cross Slopes .....	35
Table 4-3 – MCDOT Standard Inlets .....	37
Table 4-4 – MCDOT & MSHA GRATES.....	40
Table 4-5 – Access Spacing.....	40
Table 4-6 – Elliptical and Circular Pipe .....	49
Table 4-7 – Culvert Service Life .....	52
Table 4-8 – Material Rating For Service Life.....	52
Table 4-9 – Ditch Lining & Velocity .....	62
Table 4-10 – Riprap Classification.....	65

## Table of Figures

Figure 4-1 – Bicycle Safe Grate Options .....	39
Figure 4-2 - Hydraulic Grade Line .....	43
Figure 4-3 - Headloss through a Junction .....	46
Figure 4-4 - Head Loss Through a Field Connection.....	47
Figure 4-5 - Culvert Skew Length.....	53
Figure 4-6 - Culvert Skew Length.....	53

## Appendices

- Appendix A** – County Checklists
- Appendix B** – Design Tables
- Appendix C** – RCP Loading and Bedding Details
- Appendix D** – Design Spreadsheets

## Preface

In 1968 House Bill (H.B.) No. 629 was enacted by the General Assembly of Maryland, transferring the jurisdiction over storm drainage systems within Montgomery County from the Washington Suburban Sanitary Commission (WSSC) to Montgomery County. The portion of the City of Takoma Park, lying within Montgomery County after June 30, 1968 was exempted from transference of the storm drain system. H. B. No. 629 went into effect on July 1, 1968. Pursuant to the legislation, Montgomery County's Department of Public Works, which is now the Department of Transportation (MCDOT), approved its first Storm Drain Design Criteria on July 1, 1968. Subsequently, some minor changes were incorporated into the Storm Drain Design Criteria to reflect technological advances. Since the inception of the storm drain design criteria in 1968, the criteria has been updated or revised in 1975 and 1988 and has now been in effect for over thirty five years.

Consequently, in an effort to keep up with the state of the art in storm drain design and to provide more compatibility with the criteria of other local, State and Federal agencies, MCDOT has developed this document to replace the 1988 criteria. Review of this set of criteria has been in conjunction with the Montgomery County Road Code Committee (ROCOCO). ROCOCO represents local engineers, land surveyors, public utilities, developers and other government agencies.

MCDOT and Montgomery County Department of Permitting Services (MCDPS) have the authority to implement the Montgomery County Government Drainage Criteria as outlined in this manual. MCDOT handles the review of storm drain capacity & impact analyses at the preliminary plan stage to determine if any improvements are needed by an applicant to the downstream County storm drain system; handles the design and construction of County storm drain systems through Capital Improvements Program projects; and maintains the County storm drain systems within County rights-of-way and easements. MCDPS handles the review and approval of construction drawings for County storm drain systems (and the connections of private storm drain systems with County storm drain systems), issues the necessary permits, inspects the permitted construction, and then accepts the completed system for County maintenance. Drainage design approval is not the same as storm water management approval. Stormwater review shall be coordinated through the MCDPS Water Resources Section.

Criteria in this document apply only to storm drain systems maintained by MCDOT; Maryland State Highway (MDSHA) and municipalities within Montgomery County may require different design criteria. The drainage criteria in this manual are to be used in conjunction with the Montgomery County Department of Transportation's Design Standards and construction policies. This manual provides the guidelines for designing typical drainage systems and structures. The criteria does not address all unusual situations that require unique solutions by the Design Engineer and the need to allow users some flexibility with respect to its application is apparent. At their discretion, MCDOT or MCDPS will approve special designs in extenuating circumstances with adequate documentation presented by the Design Engineer.

Table A contains the municipalities within Montgomery County that are considered Special Taxing Districts. (Tax District symbols are in parentheses). These municipalities have their own planning authority which maintains their own roads and storm drainage systems. For those Special Taxing Districts in which the storm drain system is maintained by Montgomery County (and the special Taxing District pays a storm drain tax to Montgomery County), the MCDOT review will be limited to the storm drain capacity and post-development impact analysis (as part of Executive Regulation No. 28-06AM).

**Montgomery County  
Department of Transportation**

---

**Table A – Montgomery County Municipalities Supported by Storm Drain Tax**

<b>MAINTAINED BY COUNTY</b>		<b>NON-MAINTAINED BY COUNTY</b>	
Battery Park	(M11)	Barnesville	(M14)
Chevy Chase Section #3	(M05)	Brookeville	(M20)
Chevy Chase Section #4	(M05)	Friendship Heights	(M01)
Chevy Chase Section #5	(M05)	Gaithersburg	(M13)
Chevy Chase View	(M10)	Garrett Park	(M17)
Chevy Chase Village	(M04)	Kensington	(M22)
Drummond	(M02)	Laytonsville	(M15)
Glen Echo	(M18)	Poolesville	(M16)
Martin's Addition to Chevy Chase	(M08)	Rockville	(M12)
North Chevy Chase	(M09)	Takoma Park	(M23)
Oakmont	(M03)	Washington Grove	(M21)
Somerset	(M19)		

# **1 INTRODUCTION**

## ***1.1 Purpose of the Drainage Design Criteria***

The information contained herein, covers the minimum standard criteria to be followed by Design Engineers when preparing plans for construction of County storm drain systems within the jurisdiction of the Montgomery County Department of Permitting Services (MCDPS) and the Montgomery County Department of Transportation (MCDOT). Criteria contained herein cover such aspects as document submissions, right-of way/easements, hydrology, and hydraulics.

A storm drain system is defined as a network of open channels and underground pipes designed to capture and convey concentrated storm water flows to a point beyond the limits of the property being developed. County storm drains convey storm water within the limits of Montgomery County right-of-way; whereas, private storm drains convey storm water within the limits of privately owned property. Any reference within the storm drain criteria to “public” indicates facilities contained within Montgomery County Property or easements. Storm drain design of systems within Maryland State Highway Administration (MSHA) property or other state/federal lands shall default to that agencies guidelines within the limits of their property.

MCDPS reviews and approves permits relating to developments requiring publicly maintained storm drain systems, connections of private drain systems to public systems, improvements to existing public storm drain facilities, and/or plan approval for subdivision development. Storm drain facility improvements include, but are not limited to, the enclosure, channelization and stabilization of natural channels resulting from property development.

A waiver may be obtained from MCDPS to exempt a project from having to provide a formal MCDPS permit submission. A formal permit submission includes plans, calculations, reviews, and approvals of proposed storm drain systems. To obtain a permit submission waiver, the project must meet all of the following criteria:

- The project is located entirely on private property
- The peak 10-year design discharge from the site is less than 3 cubic feet per second
- The site runoff requires no connection to a Montgomery County storm drain system

Projects that are part of the MCDOT Capital Improvements Program (CIP) are the exception to the MCDPS permit submittal process. MCDOT projects shall utilize the following criteria to the maximum extent possible for the prescribed project.

## ***1.2 Laws Ordinances and Policies***

While the criteria contained in this manual are intended to be a guideline for the design and construction of storm drainage systems within Montgomery County, it shall remain the Design Engineer's responsibility to review and verify the applicability of all material presented herein as it pertains to the specific project under design. The design engineer shall submit all plans, maps, design computations, work sheets, and required easements to MCDPS or MCDOT for review and approval.

It shall be the responsibility of the developer and the design professional to be aware of all applicable laws, ordinances, and policies associated with the storm drain systems for projects under design and construction. The following is a partial list of laws and ordinances that may pertain to the project.

- 401 and 404 Permits – Joint Permit Application for Wetlands and Waterways
- Montgomery County Department of Environmental Protection (MCDEP) – Erosion and Sediment Control Permit
- Montgomery County Sump Pump Discharges

The Capital Improvements Program (CIP) involves three significant factors that include the following:

## **Montgomery County Department of Transportation**

---

- Identification of Needs,
- Readiness for Planning, and
- Affordability

The Montgomery County CIP is based on planning for a six year period and the budget for the MCDOT is divided among the following project categories.

- Bridges,
- Highway Maintenance,
- Mass Transit/Wmata,
- Parking,
- Pedestrian Facilities/Bikeways,
- Roads, and
- Traffic Improvements
- Conservation of Natural Resources

Storm drains are an important aspect that pertains to each of the categories listed. Adequately designed storm drain systems add to the long term functionality of capital improvements within Montgomery County.



## ***1.3 Right-of-Way, Easements, Ownership, and Maintenance***

### **1.3.1 General Policy**

County storm drain systems require right-of-way or easements to allow construction and long term maintenance of the storm drain systems. Typically, a storm drain system consists of ditches, inlets, storm drains, culverts, channels, and/or riprap. The entire storm drain must be contained within project right-of-way or an easement. Adequate width must be obtained for storm drain systems including headwalls, end sections, inlets, and riprap.

Any concentrated flow of  $\geq 3$  cubic feet per second (cfs) entering or crossing a right-of-way or entering a site, shall be contained in an engineered ditch, channel, culvert, or enclosed storm drain system and contained within public or private easement.

- 1) County storm drain systems parallel to roadway
  - a) Where possible, storm drains shall be located within the right-of-way specified for context sensitive design standards. Where this is not possible, any storm drain system parallel to the roadway typical section on MCDOT projects shall be considered for right-of-way acquisition. Consideration for acquisition of right-of-way will be required where:
    - the easement would overlap right-of-way
    - the easement is within 10 feet of existing or proposed right-of-way
  - b) Right-of-way shall have a minimum clearance of 5 feet from the outside of the drainage pipe/structure to the right-of-way line. Additional clearance is required for deep storm drain systems.
  - c) Where possible, storm drain systems shall be kept off lots along the road frontage to minimize right-of-way acquisition along road frontage. Storm drain easements, herein referred to as S.D. easements may be utilized for storm drain system maintenance.
- 2) County storm drain systems crossing roadway right-of-way
  - a) Any County storm drain crossing the roadway shall be contained within right-of-way or have an easement for construction and long term maintenance of the system. Where any storm drain extends beyond the limit of project right-of-way, the portion of the system outside of right-of-way will be contained in an S.D. Easement (as required in Section 1.3.2). S.D. Easements shall have adequate width for the pipe or channel plus width for a 10-foot wide (minimum) equipment access from one side of the storm drain system and a 2-foot offset from the other side of the storm drain. Easements shall extend a minimum of 20 feet upstream or downstream of the facility inlet or outlet for countermeasures and maintenance. Where the outfall riprap calculations dictate the need for more than 20' of riprap beyond the R/W, additional easement shall be procured for riprap outfall maintenance.
  - b) Subsurface drainage facilities which convey discharge from a public right-of-way shall be enclosed within a public storm drain easement (as required in Section 1.3.2) unless the County stipulates other limits to their maintenance responsibility.
  - c) Easements may be shortened to avoid impacts to or lengthened to protect environmental features. Environmental features may include wetlands, trees, natural channel banks, rock outcrops, and springs. The designer shall include adequate notes and details (i.e. symbols for wetland limits/buffer, tree details, rock limits) on the plans to indicate why the easement was modified.
- 3) Stormwater management features
  - a) Any stormwater management facilities to be maintained by Montgomery County are to be included in roadway right-of-way per Standard No. 040.00 – Stormwater Management in the Context Sensitive Road Design Standards.
  - b) Stormwater management facilities outside of right-of-way that are to be maintained by

**Montgomery County  
Department of Transportation**

---

- the County shall be enclosed within a public storm water management easement, which shall include an access strip surrounding the facility unless the County stipulates other limits to their maintenance responsibility.
- 4) Natural and improved channels
    - a) For natural drainage systems, Montgomery County does not own or maintain any FEMA regulated 100-year floodplain unless it is contained within the limits of County right-of-way or easements. Impacts to FEMA regulated floodplains shall be avoided if possible. Any project impact(s) to a FEMA regulated 100-year floodplain that obstructs flow through or causes an increase in the area of the floodplain shall be enclosed by a S.D. Easement.
    - b) For improved channels, no change to the FEMA regulated 100-year floodplain shall be permitted unless authorized by the MCDOT. Where an increase in the 100-yr floodplain occurs, the impacted area shall be enclosed by a S.D. Easement. Where no impacts occur, a S.D. Easement will contain both sides of the improved channel for the purpose of access and maintenance.
    - c) Improved and natural channel floodplains are also subject to Chapter 19, Article III of the Montgomery County Code. See the Code for permitting requirements. Within Montgomery County, the 100-year floodplain is defined as any channel/floodplain with a drainage area that meets or exceeds 30 acres.
    - d) Natural Channel designs for mitigation shall have easements on a case-by case basis depending on property ownership and monitoring requirements of the Federal/State permits. Where feasible, stream restoration / relocation shall be reverted back to the property owner upon completion of monitoring requirements.
  - 5) Private development roads
    - a) MCDOT does not operate or maintain storm drains on private development roads or parking lots outside of County right-of-way or easements.
    - b) Private development and private drainage systems are subject to the approval of Maryland-National Capital Park and Planning Commission (M-NCPPC) during preliminary studies. For private drainage systems that connect to public systems, please see Section 1.3.1.7.
    - c) Surface drainage facilities conveying storm water from upstream lots shall have private easements where the private system connects to the public system as authorized by MCDPS.
    - d) All existing or proposed surface drainage facilities such as swales, streams, storm water management facilities, unpaved or paved channels, etc., located within privately owned easements or on privately owned land with no public easement shall be the legal responsibility of the property owner, easement holder and/or Home Owners Association for operation and maintenance in accordance with County regulations.
  - 6) Discharge and S.D. easements:
    - a) Discharge easements obtained by the responsible party for the storm drain will be required from the downstream property owners if:
      - The point of discharge has been converted from sheet flow to concentrated flow
      - The point of discharge has been altered in location
      - There is an increase in the design storm peak discharge.
    - b) S.D. easements for the drainage system will be required from upstream property owners if one or more of the following conditions occur:
      - The point at which the flow crosses the property line is altered in location or becomes concentrated. The developer shall be required to construct all facilities to direct storm water runoff to the new point of entry.
      - The new development causes the hydraulic grade line for the upstream closed conduit system to be raised above the predevelopment elevation at the nearest

- upstream structure. .
  - The new development causes the hydraulic grade line in the open channel at the property line to be raised above the computed value prior to development of the site.
  - There is undeveloped land upstream and a proposed project improvement, other than a bridge or culvert, would raise the hydraulic grade line at the property line above the 100-year floodplain based on the existing natural upstream channel and the ultimate runoff of the fully developed watershed. A S.D. easement shall be required only if the backwater or headwater at the property line exceeds the previously defined 100-year floodplain by one foot for a bridge or for a culvert. In no case shall an increase be allowed at the property line, with or without a S.D. easement, if it causes flooding or increased flooding of existing structures.
- 7) Private storm drain connections to public systems:
- a) All private storm drain connections to public storm drain systems must be approved and permitted by MCDPS. Where approved and permitted, deed reference and plat information must be clearly shown on the construction plans.
  - b) Private storm drain structures are prohibited within the County storm drain easement.
  - c) All private pipe and structures including the connecting pipe to the first public structure shall be maintained by the property owner or the homeowner’s association.

**1.3.2 Storm Drain Easements**

At preliminary plan submission, the storm drain designer shall review the proposed right-of-way limits to ensure that proposed storm drains are contained within the right-of-way established for the Montgomery County Context Sensitive Road Design Standards (Executive Regulation No. 31-08A and errata). Where storm drains or storm water management BMP swales or channels extend beyond the limits of right-of-way, the designer shall ensure that both existing and proposed storm drain systems, owned by MCDOT, are contained within right-of-way or Storm Drain (S.D.) Easements at the conclusion of the plan development. Existing storm drains without existing S.D. easements shall be brought to the attention of the MCDOT. The designer shall provide appropriate adjustments to any existing or proposed public utility easements that may come in conflict with the storm drain easement.

The following guidelines are to establish minimum easement widths for storm drain installations deeper than five feet. Establishment of minimum easements should be reviewed by the designer for constructability; however, means and methods of construction are considered to be the responsibility of the contractor. The contractor is expected to utilize applicable OSHA rules and regulations for excavation and shoring to provide a safe work area and keep construction within the easement shown on the construction plans.

**1.3.2.1 Standard Pipe Systems (12 feet deep or less)**

The following right-of-way easement widths (Table 1-1) are estimated based on construction depth of less than 12 feet (finished grade to invert). It is assumed that pipes and structures can be constructed or maintained using a standard 12 foot deep (or smaller) trench box. These widths are to be used as a guideline; however, in no case shall the easement be less than 5 feet from all outside edges of pipes, manholes, inlets or drainage structures designed for the system.

**Table 1-1 - Minimum Right-of-Way**

<b>Pipe Size</b>	<b>Easement Width</b>
<i>(in)</i>	<i>(ft)</i>
15" to 24"	20'
27" to 48"	25'
54" to 72"	30'

### **1.3.2.2 Deep Pipe Systems (greater than 12 feet deep)**

Deep pipes are considered to be installed at depths ranging from 12 feet to 20 feet below ground elevation. Where standard depth storm drains ( $\leq 12$  feet deep) may be utilized, the use of deep pipes shall not be allowed. Where deep pipes are required, the design engineer is required to obtain approval from MCDPS or MCDOT prior to design.

Easements for deep pipes are based on the assumption that a 12 foot deep trench box will be utilized to excavate and repair the conduit and bedding. Any pipe design that is greater than 20 feet deep must be approved by MCDPS or MCDOT drainage and right-of-way divisions prior to final design. Any pipe or storm drain system installed deeper than 12 feet shall be concrete and have the diameter increased by 6-inches to allow lining of the pipe for future maintenance. In the event that the pipe run returns to less than 12 feet deep, the pipe diameter may be returned to smaller diameter with approval of MCDPS or MCDOT. Distance to next downstream pipe size transition shall be presented to MCDPS or MCDOT for consideration of the pipe size reduction. Reduction in size will rarely be warranted if system continues to collect additional runoff.

The following equation can be used to estimate a required easement width; however, it is to be used for estimating purposes only. Required easement width shall be established during approval by the MCDPS or MCDOT permit approval process.

$$W_E = B_D + 4(D - 12') + 12' \qquad 1-1$$

Given:

$W_E$  = Easement Width for deep pipe (ft)

O.D. = Outside Diameter (ft)

$B_D$  = Trench Width\* either  $2(O.D.)$  or  $(O.D. + 3')$  whichever is narrower (O.D. = Outside Pipe Diameter)

$(D - 12')$  = Depth from ground line to invert of pipe minus trench box depth

4'  $\Rightarrow$  2:1 slopes on both (2) sides of the trench

12'  $\Rightarrow$  10-foot equipment passage one side + 2-foot other side

\* - See trench details in Appendix C for equation for trench width

### **1.3.3 Channels and Outlets**

At storm drain system entrances and outlets, including all transitions to meet existing conditions, the easements shall be of sufficient width to accommodate access by maintenance equipment. The permanent easement width at proposed channels and transitions shall include:

- a 10 foot wide access area for maintenance equipment along one side of the trench and
- a 2 foot wide area along the opposite side of the trench

The easement width is to facilitate long term maintenance of the storm drain inlet or outfall. . The permanent easement shall extend 20 feet in length beyond the limits of the proposed channel construction (including transitions to existing ground).

### **1.3.4 Maintenance & Access**

The County provides maintenance and repair of County storm drainage systems, ditches, outlet protection, culverts, and channels. The majority of these systems are located within County right-of-way or recorded easements.

Where easements are not identified, the County shall only maintain the drainage system or channel to the limit of County right-of-way or 20 feet from the limit of the constructed feature when access is granted by

the property owner.

Where private storm drains or storm water management is located within County right-of-way, the entity dedicated to perform maintenance must be identified on the construction plans and all declarations and agreements must be signed and approved by MCDPS as part of the permit requirement prior to construction.

Access to recorded public easements should be by County officials, employees, or representatives of the County (consultants, contractors, etc...). General public access is not implied by easements.

### **1.3.5 Connection to existing Storm Drain Systems**

During the course of design, there are times when a proposed County or private storm drainage system may require connection to an existing County or private storm drainage system.

Storm drain systems owned and operated by Montgomery County should not be connected to private storm drains where avoidance is possible. Where avoidance is not possible, the private storm system should be analyzed and taken into the County storm drainage system as a storm drain trunk line from the point of connection to the point where the system discharges to a ditch, constructed channel, or natural channel. Lateral systems shall be analyzed for adequacy and shall become part of the County storm drain system as directed by MCDOT or MCDPS based on the purpose and need of the project. At a minimum, the County system must extend to the nearest downstream structure capable of overflow without impact to the upstream system. All private storm drain systems incorporated into the County storm drain system shall be required to convey the appropriate design discharges for the functional classification and be contained within an appropriately sized easement.

Private storm drain systems that connect to County storm drains must be analyzed to ensure that the proposed connection will not surcharge pipes within the County storm drain system. When the proposed connection is part of a project with storm water controls, the connection can be approved if the post-development runoff is equal to or less than pre-development runoff. For projects where storm water management is not implemented, the proposed peak discharge from the site must not surcharge the existing County storm drain system for the design storm. Where the pre-development discharge is greater than the proposed design discharge, the first section of existing pipe must be analyzed to ensure adequate capacity is available for the existing condition. When the design discharge is greater than the existing condition, the designer shall analyze the complete storm drain system to a point where three consecutive storm drain pipe runs are able to convey the proposed peak design discharge without surcharging the system.

Where storm drain systems surcharge or are not sized correctly, the County may require the developer to upgrade the system to the point where the system is appropriately sized or provide on-site storage. When the system is upgraded, an updated storm drain easement will be required.

## 2 SUBMISSION AND APPROVAL PROCEDURES

### 2.1 Drainage Study

#### 2.1.1 General Information

The Montgomery County Department of Transportation (MCDOT) drainage study, herein referred to as the Drainage Study, shall contain calculations and supporting data used in the storm drain design.

Drainage Study calculations and supporting data shall include the following:

- Drainage Area Map
- Hydrologic Calculations
- Hydraulic Calculations
- Structural Computations (for non-standard structures)
- Hydraulic Gradient Profiles

Storm drain systems shall be designed on the basis of ultimate development of the tributary watershed. The Maryland-National Capital Park and Planning Commission (M-NCPPC) should be consulted by the Design Engineer to obtain the latest zoning or the latest adopted master plan to determine the type of future development expected within the contributing watershed(s).

The Design Engineer may be able to obtain Geographic Information System (GIS) data from the Montgomery County Department of Technology Services – Geographic Information Systems Services or other government agencies to supplement construction plans or maps for various aspects of the project. This data may include soils maps, off-site contours, streams, wetlands, tax map parcels/tiles, and land use. The County GIS information is available online at <http://www.montgomerycountymd.gov/gistmpl.asp>.

For private projects, MCDOT reviews Drainage Study submittals at the preliminary plan stage to identify existing County-maintained storm drain systems downstream of the proposed private development. If an existing downstream system is identified, MCDOT reviews the impact to determine whether the runoff will exceed the capacity of the system based on the appropriate design storm event (as noted in Section 3). If the design storm exceeds the capacity of the system, the development applicant will be required to either upgrade the system accordingly or increase the capacity of the proposed storm water management/quantity reduce the runoff to the capacity of the downstream drainage system. When required to upgrade the downstream system, a proposed project must be relevant to and proportional to the proposed project. Where the cost of providing the upgrades are not compatible to the cost of the proposed project, the project may be assessed for a waiver. Upon meeting the requirements for the downstream County-maintained storm drain system, MCDOT does not review design details of on-site open or enclosed storm drain systems.

Drainage Studies for projects designed and constructed as part of the MCDOT CIP are reviewed and approved solely by MCDOT and are not reviewed or approved by MCDPS.

On private projects, an approved Drainage Study is required as supporting data for plan submission to MCDPS. The following plan review checklists have been included in **Appendix A**.

- Grade Establishment Plan Review Checklist
- Storm Drain and/or Paving Plan Review Checklist

Drainage Studies submitted for both County, private, or MCDOT projects must be sealed and signed by a Professional Engineer (PE) or Professional Land Surveyor (PLS) licensed in the State of Maryland.

### **2.1.2 Drainage Area Map**

The drainage area map should be based on the most recent and accurate topographical data available. Recent field run or aerial photogrammetric topography and site grading plans are preferable. Where aerial photogrammetric mapping is used, it may be necessary to supplement with field run topography. In any case, the Design Engineer is expected to field verify the actual drainage patterns by field inspection of the site. The tributary area is that area from which storm runoff flows to the study point.

The following items are required for a drainage area map to be considered complete and ready for review:

- Sheet Size and Layout
  - The minimum size of the drainage area map shall be 24-inch by 36-inch. (Exceptions may be made to allow a maximum size of 30" by 42" for larger offsite drainage areas)
  - For large projects with multiple sheets or different scales, a key sheet shall be required; however, where multiple sheets are utilized the sheets should be uniform scale unless warranted by special conditions at the site.
  - The scale shall be 1" = 200'. Other scales may be used when a large off-site area is involved or to provide clarity of small areas. Supporting topographic information shall be provided when scales other than 1" = 200' are used.
  - At least 500 feet of the downstream drainage course shall be shown.
- Existing topography and mapping shall include:
  - Existing contours
    - 1-foot or 2-foot intervals (unless otherwise approved)
    - Field survey for project site and GIS contours for offsite areas (*if needed*)
    - Provide perimeter around field survey with label "Limit of Field Run Survey"
  - Existing Major and Minor streets within the drainage area
  - Outline of the proposed development site (*Limit of Disturbance*) shall be shown to properly locate the area under consideration.
  - Land Use and Zoning (Parcels, School Sites, Parks, etc...)
  - Soil Data
  - Existing streams and defined swales shall be shown (named waterways shall be identified and all watercourses shall have flow direction and label).
  - Existing storm drain systems (include pipes and structures labeled as existing)
  - Future or approved storm drain systems, storm water management, or flood control (not yet constructed but not part of the proposed project)
  - The 100 year flood plain limits of surface drainage courses shall be shown for drainage districts that have contributing drainage areas greater than 30 acres.
- Proposed topography and mapping shall include
  - Proposed Contours (match interval for existing contours)
  - Proposed streets or development
  - Outline of the development (Limit of Disturbance)
  - Proposed Storm Drain systems (include pipes and structures labeled as proposed)
  - All structures shall be numbered and pipes labeled to correspond with the storm drain and

- paving plans and the storm drain report submitted for approval.
- Drainage area line styles shall apply as follows:
    - Overall drainage area boundary serving all storm drain system shall be outlined by a solid line; thereby, enclosing all the sub-drainage areas.
    - Sub-drainage/tributary areas to each inlet structure shall be delineated by dashed lines. The area, in acres, of every tributary area shall be shown near the structure.
    - Time of Concentration path shall consist of a dot-dash line style (segments labeled to match Tc Calculations)
    - Study Point indicating where the point discharge for the drainage area is calculated shall be denoted for each analyzed watershed using an asterisk symbol.
    - All line styles shall appear in the legend with the appropriate label
  - General information required on the plans shall include:
    - Title block containing
      - Project or Subdivision name
      - Engineering firm's name and address
      - Date prepared
    - North Arrow
    - Scale (appropriately marker for each sheet)
    - Legend
    - Flow direction within each tributary area shall be identified by either a sufficient number of flow arrows or contour lines.

### **2.1.3 Hydrologic Calculations**

At a minimum, the Drainage Study shall include any of the following calculations and supporting data that were required for design at the project site.

- Drainage Area
- Runoff Coefficients
- Rainfall Intensity or Depth
- Time of Concentration
- Discharges
- Site Inventory (See Section 4.4.4)

### **2.1.4 Hydraulic Calculations**

At a minimum, the Drainage Study shall include any of the following calculations and supporting data that were required for design at the project site.

- Ditch or channel analysis (velocity, depth, shear)
- Gutter spread
- Inlet selection, interception, and bypass
- Storm drain design (pipe size, capacity, cleanout velocity, hydraulic grade line calculations)
- Hydraulic analysis shall be performed without Stormwater Management for the 10-year design storm.
- Culvert design



- Inlet and outfall protection

### **2.1.5 Miscellaneous Calculations**

Drainage Study calculations and supporting data shall include the following:

- Structural Computations (for non-standard structures)

## **2.2 Plan Permit Submittals**

### **2.2.1 Permit Submittal requirements**

Submittals to MCDPS for the review and approval of storm drain plans shall include the following:

- MCDPS' Standard Checklist for Grade Establishment Review Checklist. (Included in Appendix A)
- MCDPS' Standard Checklist for Storm Drain and/or Paving. (Included in Appendix A)

NOTE: Storm drain and paving plans will not be accepted for review until the grade establishment plans have received final approval unless approved in writing by MCDPS.

Submittals are to be made to MCDPS. After the plans have received final approval, they are returned to the Design Engineer who may then submit a Permit Submittal Package to MCDPS for processing.

Upon completion of the design and approval of permits, the following aspect of the design shall be submitted to the county in a GIS format to allow the county to maintain the County database. GIS format submission will be in shapefile format in Maryland State Plan Projection. Upon completion of construction, the GIS data must be obtained and updated by the Engineer performing the as-built certification.

- Storm Drain system

### **2.2.2 Storm Drain Plans**

The following items shall be included on construction plan sheets for drainage features or any other items listed on the storm drain and paving checklist and grade establishment checklist.

#### **2.2.2.1 Existing Conditions**

- Drainage Right-of-Way or Easements
- Existing Drainage Features (**See also 4.4.4 Site Inventory**)
- Pipe (Type, Size, Elevation, and Flow Arrows)
- Culvert (Type, Size, Elevation, and Flow Arrows)
- Ditches (Spot Elevations, Transitions, and Flow Arrows)
- 100-Year Floodplain Elevation

#### **2.2.2.2 Proposed Conditions**

- Proposed Drainage Right-of-Way or Easements (Plat Numbers for connection of private storm drain to County storm drain systems)
- Proposed Drainage Features
- Pipes (Type, Size, Elevation, and Flow Arrows)
- Culverts (Type, Size, Elevation, and Flow Arrows)
- Ditches (Spot Elevations, Transitions, and Flow Arrows)
- Pipe schedule, showing lengths, pipe sizes, materials, and class or gauge

- Structure schedule showing structure types, elevation, dimensions with proper reference to Montgomery County, WSSC, and MSHA standard detail numbers for each structure
- Structure numbers to match structure schedule, pipe profiles, and drainage study
- Required storm drain easements whether shown on record plat or recorded by separate instrument
- Outfall Treatment with existing topography to a limit of 100 feet below outfall.
- Details for special structures, typical sections, etc., shall be of a sufficient scale for clarity.
- Utility Crossings. Storm drain pipes shall cross utilities perpendicularly whenever possible. Where crossings cannot be perpendicular, they will be at an angle no more than 45° from perpendicular.
- Drawings shall be prepared on tracings suitable for ready reproduction and microfilming with a maximum size of 24" by 36" and a minimum size of 18" by 24".
- All supporting data shall be a minimum size of 8 1/2" by 11".
- A scale of 1" = 4' or 1" = 5' is preferred for details of special structures; however, final size shall be based on the size and detail required for the structure.
- Plans, profiles, special details, typical sections, etc. shall show the scale.
- Plans shall show clearly all proposed construction including street paving and other improvements, existing or approved storm drains, sewers, water mains, water and sewer services, gas mains, poles, conduits, or other utilities, streams, property lines, easements, rights of way, property ownership where applicable, and other pertinent data
- Structural details of any structures which are not W.S.S.C., Maryland State Highway Administration (MSHA), Montgomery County or other recognized standards shall be shown on the plans, and computations must be submitted to show that they have adequate strength and hydraulic efficiency
- Each drawing must bear the professional seal, signature, registration number and license expiration date of the Registered Professional Engineer (PE) and/or Professional Land Surveyor (PLS) that is registered by the State of Maryland and who is responsible for the design. The first drawing shall have a certification, by the professional, that the design conforms to these criteria.
- Notes common to all drawings shall be shown on the first sheet of the set of plans and labeled "General Notes for Storm Drain Construction."
- All necessary stake-out information shall be clearly shown on the plans and all structures, as well as drains laid on curves, shall be plainly located by dimensions from property lines, centerline street stationing or existing structures.
- A tabulation of the type, size, and top elevations of structures and a tabulation of sizes, lengths, and types of pipe used shall be shown.

Plans shall clearly show all proposed construction, including street paving and other improvements, all existing and/or proposed utilities including storm drains, water mains, sewer mains, wells, septic systems, gas mains, poles, conduits, and other utilities as applicable, streams, property lines, easements, rights of way, property ownership, where applicable, and other pertinent data making use of the Montgomery County conventional CADD Standards.

Table 2-1 provides uniform nomenclature for labeling of existing and proposed storm drain materials.

**Table 2-1 – Pipe and Culvert Material Abbreviations**

<b>Abbreviation</b>	<b>Material Type</b>
RCP	Reinforced Concrete Pipe
RCPD	Reinforced Concrete Pressure Pipe
HERCP	Horizontal Elliptical Reinforced Concrete Pipe
CMP	Corrugated Metal Pipe
CMPA	Corrugated Metal Pipe Arch
SRP	Spiral Rib Pipe
CAP	Corrugated Aluminum Pipe
ASRP	Aluminum Spiral Rib Pipe
CAPA	Corrugated Aluminum Pipe Arch
SPP	Structural Plate Pipe
SPPA	Structural Plate Pipe Arch
APP	Aluminum Plate Pipe
APPA	Aluminum Plate Pipe Arch
CPP-S	Corrugated Polyethylene Pipe (Smooth Interior)
CPP-D	Polyethylene Pipe (Smooth Interior and Exterior)
PVCWP	Polyvinyl Chloride Profile Wall
FCP	Non-Asbestos Fiber-Cement
DIP	Ductile Iron Pipe
HDPE	High Density Polyethylene

### **2.2.3 Storm Drain Profiles**

The following items shall be included on construction plan sheets for drainage features or any other items listed on the storm drain and paving checklist.

- Horizontal Scale 1" = 50'
- Vertical Scale 1" = 5'
- Structure Numbers (must match plan, structure Schedule and drainage study)
- Pipe Lengths – to be shown by stationing at each structure
- Pipe Size and Material (include class or gauge for each run)
- Quantity of Flow, Actual Slope, Minimum Slope (required to convey the design discharge) and Velocity for each run (when pipe will not flow full due to actual slope being steeper than required, actual partial flow velocity must be shown)
- Show Hydraulic Gradient on Pipes
- Utility Crossings
- Outfall Treatment – show class and length of riprap, filter cloth required and cross section of outfall channel.

### **2.2.4 Plan Notes**

General Notes for Storm Drain Construction

- 1) All storm drains shall be constructed in accordance with the latest Edition of the Standard Specifications of the Maryland State Highway Administration and Montgomery County.
  - a) Type of structure refers to the latest Design Standards of Montgomery County Department of Transportation, Standard Details of the Washington Suburban Sanitary

Commission, and Book of Standards of the Maryland State Highway Administration, unless otherwise noted.

- b) Where the drop on the main line through a structure can be accommodated by an invert slope of 1.5:1 or flatter, a rounded channel lined with sewer brick on edge shall be built to the crown of the pipes.
- c) "Information concerning underground utilities was obtained from available records. The Contractor shall determine the exact location and elevation of the utilities by digging test pits by hand at all utility crossings, well in advance of trenching. If clearances are less than specified on this plan or less than 12" when not specified, contact the Montgomery County Department of Permitting Services ROW Inspector and the appropriate utility owner before proceeding with construction."
- d) Where any part of the storm drain system is located in a fill section, provide select fill material compacted to 95% AASHTO T-99 density from approved subgrade to the structure bottom slabs and/or the pipe bedding.
- e) All storm drain pipes shall be installed with class "C" bedding as shown on Montgomery County Department of Transportation, "RCP Supporting Strength" loading charts in Appendix C.
- f) Call "Miss Utility" at 1-800-257-7777 - 48 hours prior to beginning excavation to determine the location of existing utilities (see also <http://www.missutility.net/maryland/>).
- g) All storm drain construction on this plan, except driveway culverts, to be maintained by MCDOT unless otherwise noted on the plans.
- h) All field modifications are subject to MCDPS field inspector approval.

## ***2.3 Discrepancies and Revisions***

### **2.3.1 Plan Discrepancies**

If any discrepancies or ambiguities are found to exist in these criteria, or if there are any conflicts between these criteria and any code, regulation, policy or criteria promulgated by any other jurisdictional agencies affecting the design, MCDPS shall be advised in writing and will render an expeditious interpretation and guidelines to be followed.

### **2.3.2 Plan Revisions**

Any revisions to approved storm drain plans shall be submitted to MCDPS for review and approval prior to construction.

## ***2.4 Utilities***

### **2.4.1 General**

Utilities are a method of providing various services to residential, commercial, and industrial facilities. The design engineer must be cognizant of both identified and unidentified utilities that may be present at a site. Recognizing utilities that may be encountered during design and/or construction will provide a better design and aid in reducing delays during construction if unknown utilities are encountered.

Utilities encountered in storm drain design are typically either County or private. Utilities often encountered in development include waterlines, wells, sewer mains, septic systems, gas lines, gas transmission lines, electric, cable, traffic signal interconnect, and fiber optic lines. Any buried utility or pole to support an aerial utility can be potentially impacted by storm drain design.

Locations of all existing and proposed utilities are to be shown on the plans and profiles.

### **2.4.2 Utility Identification**

During design, the Engineer will be responsible for research, collection, and collation of all pertinent data used to determine the precise location of existing utilities. Site survey of existing utilities shall include survey of utilities, poles, cabinets, hand hole box, utility markers, and any other utilities identified at the site. Additional records and maps should be requested from the assorted utility companies (identified at the project site). MCDOT should be contacted for County maintained storm drain system. The Design Engineer will be responsible for obtaining precise locations by test pits wherever exact locations of underground utilities are critical to the storm drain design, or where adjustment during construction would be costly and/or cause significant delay. The locations of all existing and proposed utilities are to be shown on the plans and profiles.

**NOTE:** It is imperative that the design engineer or test pit contractor notify Miss Utility at 1-800-257-7777 - 48 hours prior to beginning excavation to determine the location of existing utilities. (See also <http://www.missutility.net/maryland/>)

The designer should be familiar with Miss Utility Regulations associated with the Maryland Underground Facilities Damage Prevention Law (§12–101) that includes (but is not limited to):

According to the Maryland Underground Facilities Damage Prevention Law (effective October 1, 2010), licensed architects, professional engineer, professional land surveyor and landscape architects will be able to process designer tickets for projects in the planning phase. Owner members will have 15 full business days to respond to designer tickets.

An 18-inch “no mechanized equipment” zone will become a statewide requirement for excavations or demolitions, including Montgomery County.

The complete law is available for review on the World Wide Web or can be obtained from the State Government (See <http://www.missutility.net/maryland/mdstatelaw.asp>).

### **2.4.3 Utility Verification Plans & Coordination**

Utility verification plans should be coordinated with the various utility companies by the storm drain designer. At a minimum, the utility verification plans shall match preliminary plans and contain all identified existing utilities and utilities proposed for construction (if available) in the area. A transmittal letter shall request review and comment on the plans and utility location.

Upon receipt of verification plans, the designer shall update the utilities for subsequent design submissions and file the utility verification plans with the project files.

### **2.4.4 Clearance with Other Utilities**

All proposed and existing utilities crossing or parallel to storm drain systems shall be shown on the plan view.

All proposed and existing utilities crossing the storm drain pipes/structures and sewer mains parallel to the system shall be shown on the profile view.

A minimum vertical clearance of 12 inches and a minimum horizontal clearance of 5 feet, wall to wall shall be provided between storm drain pipes/structures and other utilities.

Storm drain vs. utility crossing angles shall not be greater than 45 degrees from perpendicular.

Protection shall be provided where concentrated storm water flows across the trench of other existing utilities. Trench widths equivalent to MCDOT standards shall be provided unless otherwise noted by the utility company.

### 3 HYDROLOGIC ANALYSIS

#### 3.1 General

Generally, the 10-year storm frequency shall be used in designing pavement drain systems. For culverts, the hydrologic computations will be based on the context sensitive design classification of the roadway as noted in Table 3-1 below.

**Table 3-1 - Context Sensitive Design Classification**

Standard No.	Road Classification	Design Storm	
		Pavement (years)	Culverts (years)
	Driveway	n/a	10-Year
2001.01-.03	Tertiary Residential Street	10-Year	10-Year
2002.01-.04	Secondary Residential Street	10-Year	10-Year
2003.08-.14	Primary / Principal Secondary Residential Streets	10-Year	25-Year
2004.01-.05	Country Road	10-Year	25-Year
2004.01-.06	Urban Arterial Road	10-Year	25-Year
2004.07-.16	Suburban Arterial Road	10-Year	25-Year
2004.18	Rural Arterial Road	10-Year	25-Year
2004.19-.24	Urban Minor Arterial Road	10-Year	25-Year
2004.25-.31	Suburban Minor Arterial Road	10-Year	25-Year
2004.33	Rural Minor Arterial Road	10-Year	25-Year
2004.34	Country Road	10-Year	25-Year
2004.35	Country Arterial	10-Year	25-Year
2005.01-.04	Business District Street	10-Year	25-Year
2006.01-.04	Industrial Street	10-Year	25-Year
2007.01-.03	Parkway	10-Year	50-Year
2008.01-.02	Urban Major Highway	10-Year	50-Year
2008.04	Suburban Major Highway	10-Year	50-Year
2008.05	Rural Major Highway	10-Year	50-Year
2008.07-.08	Urban Controlled Major Highway	10-Year	50-Year
2008.09-.11	Suburban Controlled Major Highway	10-Year	50-Year
2008.09-.12	Rural Controlled Major Highway	10-Year	50-Year

Based on the hydrologic criteria for Montgomery County, Table 3-2 represents the applicability of the hydrologic methods based on drainage area. The Design Engineer must determine which method is most applicable and practical for a given drainage area. Drainage area size is not the only factor in determining the best hydrologic method. In general, the Rational Method is to be used solely for determining peak discharges for homogenous watersheds. It is particularly well suited for determining discharges to individual inlets and for designing storm drain systems. The NRCS methods (TR-55, TR-20 and GIS Hydro) are better suited for determining peak discharges and hydrographs for larger and more complex watersheds. Please refer to each method's user manual for more detail on their respective applicability and limitations.

**Table 3-2 – Hydrologic Methods by Drainage Area**

Limit of Drainage Area		Hydrologic Method
Lower (acres)	Upper (acres)	
0	40	Rational Method
1	100	TR-55 Method
5	2,000	TR-20 Method
400	Undefined	GIS Hydro or TR-20

*Consult the description for each Hydrologic Method*

Computer programs and methods of design not referred to in these criteria must be documented by the Design Engineer and approved by MCDPS. All assumptions are to be identified.

### **3.2 Time of Concentration**

The Time of Concentration (TC) is the period of time required for the storm water runoff to flow from the hydraulically most distant point, representative of the tributary area, to the point under consideration. In the design of storm drain systems, the time of concentration must be determined at each point where additional water enters the system. This is done by adding to the time of concentration at the upstream point the actual time required for the water to flow through the storm drain system to the point being analyzed. The longest time of concentration to the point being analyzed which can be arrived at in this matter will be used.

The designer shall take care to ensure that the time of concentration flow path is representative of the drainage area being analyzed. If one sub-area of the modeled drainage area has a significantly higher time of concentration than any other sub-area it may not be an appropriate representation of the watershed characteristics.

The time of concentration will be calculated as follows:

#### **3.2.1 Rational Method**

For drainage areas of 2.0 acres or less, Table 3-3 is used:

**Table 3-3 – Small Drainage Area Time of Concentration**

'C' Factor	TC (minutes)
≥ 0.8	5
0.65-0.79	7
0.40-0.64	10
≤ 0.39	15

For drainage areas greater than 2 acres the TC is calculated as follows:

- Determine the flow path and length (L) from the hydraulically most distant point representative of the drainage area.
- Determine the travel time (Tt) for the first 100 feet (300 feet for special conditions) of flow length from the table above, utilizing the 'C' factor for the drainage area
- Utilize a velocity of 7 FPS for an average drainage area slope of 7% or less, or 10 FPS for an average slope greater than 7%, to determine the travel time for the remaining flow path.
- The sum of the above two travel times is the time of concentration for the drainage area. The time of concentration (in minutes) can be calculated as follows:

$$T_c = T_t + \frac{L - 100}{60V} \quad 3-1$$

Where:

T<sub>c</sub> = Time of Concentration (min)

T<sub>t</sub> = Travel Time (min)

L = Hydraulic Length (ft)

- For subdivisions of lot sizes of 2 acres or greater, if it can be shown that the drainage area will not have a closed system installed in the future, then the time of concentration can be determined utilizing the methods described in the most current release of NRCS, TR-55, Urban Hydrology for Small Watersheds, Chapter 3.

Using the computed time of concentration, the intensity can be determined from the Rainfall Intensity Duration Data table in Table 3-8, which is valid for times of concentration from 5 minutes thru 60 minutes.

### **3.2.2 NRCS (SCS) TR-55**

There are a number of methods that can be used to estimate time of concentration (T<sub>c</sub>), some of which are intended to calculate the flow velocity within individual segments of the flow path (e.g., shallow concentrated flow, open channel flow, etc.). The time of concentration can be calculated as the sum of the travel times within the various consecutive flow segments.

#### **3.2.2.1 Sheet Flow Travel Time**

Sheet flow is the shallow mass of runoff on a planar surface with a uniform depth across the sloping surface. This usually occurs at the headwater of streams over relatively short distances, rarely more than about 300 ft (on paved lots), and likely less than 100 ft. Where sheet flow is calculated over 100 linear feet, the engineer shall provide the assumptions for the distance used in design. Sheet flow is commonly estimated with a version of the kinematic wave equation, a derivative of Manning's equation, as follows:

$$T_{t_{SF}} = \frac{0.007(nL)^{0.8}}{(P_2)^{0.4} S^{0.4}} \quad 3-2$$

Where:

T<sub>t<sub>SF</sub></sub> = Sheet Flow Travel Time (min.)

n = Roughness Coefficient (See Appendix B)

L = Flow Length (ft)

P<sub>2</sub> = 2-year, 24-hour rainfall (in)

S = Slope of Hydraulic Grade Line (Land Slope ft/ft)



**Table 3-4 – Common Overland Flow Roughness Coefficients (n)**

Land Cover / Flow Regime	n	Land Cover / Flow Regime	n
Pavements and Pipe Linings	---	Grass	---
Smooth Asphalt	0.011	Short Grass	0.150
Smooth Concrete	0.012	Dense Grass	0.240
Ordinary Concrete	0.013	Bermuda Grass	0.410
Corrugated Metal Pipe	0.024	---	---
Vegetated Areas	---	Woods	---
Fallow (No Crop Residue)	0.050	Light Underbrush	0.400
Cultivated Soils	---	Dense Underbrush	0.800
Crop Residue ≤ 20%	0.060	---	---
Crop Residue > 20%	0.170	---	---
Range ( <i>Natural</i> )	0.130	---	---

Since “i” depends on  $T_c$  and  $T_c$  is not initially known, the computation of  $T_c$  is an iterative process. An initial estimate of  $T_c$  is assumed and used to obtain “i” from the IDF curve for the locality. The  $T_c$  is then computed from Equation 3-2 and used to check the initial value of  $T_c$ . If they are not the same, the process is repeated until two successive  $T_c$  estimates are the same.

Based on the “Hydrology Technical Note No. N4” (Dated 1986) by the United States Department of Agriculture (USDA) Natural Resources Conservation Service (NRCS), it has been found that the Manning-kinematic solution is sound, defensible, and easy to use. Therefore, it is recommended that this equation be used to compute  $T_t$  for the overland flow segment. The maximum flow length of 300 feet with a most likely length of 100 feet should be used in overland flow computations for unpaved areas. Paved areas may have longer lengths of sheet flow until flow becomes channelized in gutters or low areas of parking lots. The range of mean depth is 0.002 feet for paved areas to 0.02 feet for vegetated areas. Where lengths greater than 100-feet are used, the design engineer shall show that the mean depths of 0.002 feet (paved) or 0.02 feet (vegetated) are not exceeded for the project specific length.

### 3.2.2.2 Shallow Concentrated Flow

After short distances of at most 100 m (300 ft), sheet flow tends to concentrate in rills and then gullies of increasing proportions. Such flow is usually referred to as shallow concentrated flow. The velocity of such flow can be estimated using the general equations outlined in TR-55 for unpaved or paved flow path.:

$$V = 16.1345\sqrt{S} \quad (\text{Unpaved}) \quad 3-3$$

$$V = 20.3282\sqrt{S} \quad (\text{Paved}) \quad 3-4$$

Where:

V = Average Velocity (fps)

S = Slope of the Hydraulic Grade Line (watercourse slope ft/ft)

The nomograph from the Urban Hydrology for Small Watersheds, TR-55 (dated June 1986) named “Average Velocity for Shallow Channel Flow” utilizes equations 3-3 and 3-4 and is still applicable.

$$Tt = \frac{L}{3600(V)} \quad 3-5$$

Where:

- Tt = Trave Time (hr)
- L = Length of Flow (ft)
- V = Average Velocity (fps)
- 3600 = Conversion factor from seconds to hours

### 3.2.2.3

#### 3.2.2.4 Open Channel Flow

Flow in gullies empties into channels or pipes. Open channels are assumed to begin where either the blue stream line shows on USGS quadrangle sheets or the channel is visible on aerial photographs. Cross-section geometry and roughness should be obtained for all channel reaches in the watershed. Manning's equation can be used to estimate average flow velocities in pipes and open channels as follows:

$$V = \frac{Ku}{n} R^{2/3} S^{1/2} \quad 3-6$$

Where:

- V = Velocity (fps)
- Ku = Empirical Coefficient equal to 1.49 (1 SI)
- n = Roughness Coefficient (See Appendix B)
- R = Hydraulic Radius (ft) "Flow Area / Perimeter"

For a circular pipe flowing full, the hydraulic radius is one-fourth of the diameter. For a wide rectangular channel ( $W > 10 d$ ), the hydraulic radius is approximately equal to the depth. The travel time is then calculated as follows:

$$Tti = \frac{L}{60(V)} \quad 3-7$$

Where:

- Tti = Travel Time for segment I (min.)
- L = Length of Segment (ft)
- V = Velocity for Segment (fps)

## Peak Discharge Computations

### 3.2.3 Rational Method

One of the most commonly used equations for the calculation of peak flow from small areas is the Rational formula, given as:

$$Q = C_f \frac{CiA}{K} \quad 3-8$$

Given:

- Q = Peak Discharge (cfs)
- C<sub>f</sub> = Correction Factor for storm events greater than 10-year (See Table 3-7)
- C = Dimensionless Runoff Coefficient (See Table 3-6)
- i = Rainfall Intensity (in/hr)
- A = Contributing Drainage Area (acres)
- K = Units Conversion factor 1 English (360 SI)

Assumptions inherent in the Rational formula are as follows:

- Peak flow occurs when the entire watershed is contributing to the flow.
- Rainfall intensity is the same over the entire drainage area.
- Rainfall intensity is uniform over the time duration equal to the time of concentration, t<sub>c</sub>. The time of concentration is the time required for water to travel from the hydraulically most remote point of the basin to the point of interest.
- Frequency of the computed peak flow is the same as that of the rainfall intensity, i.e., the 10-year rainfall intensity is assumed to produce the 10-year peak flow.
- Coefficient of runoff is the same for all storms of all recurrence probabilities.

Because of these inherent assumptions, the Rational formula should only be applied to small drainage areas as follows:

- Drainage areas up to 5 acres for a single inlet contributing to an enclosed storm drain
- Enclosed storm drainage systems not to exceed 40 acres

#### 3.2.3.1 Runoff Coefficient

The runoff coefficient, C, in Equation 3-7 is a function of the ground cover and a host of other hydrologic abstractions. It relates the estimated peak discharge to a theoretical maximum of 100% runoff. Typical values for C are given in **Table 3-6**. If the basin contains varying amounts of different land cover or other abstractions, a composite coefficient can be calculated through weighing as follows:

$$C_{WEIGHTED} = \frac{\sum C_x A_x}{A_{TOTAL}} \quad 3-9$$

Given:

x = Subscript designating values for incremental areas with consistent land cover

In computing flow to any point under consideration, the runoff coefficient shall be a composite of the ultimate development "C" factors for all areas tributary to the point. In areas where the nature of future development is uncertain, the design shall be based on a "C" factor for the anticipated future type of development. If lack of zoning for a particular area does not allow an estimated land use, use a "C" factor comparable to that of adjacent developed areas.

"C" factors for development shall represent a weighted average based upon the proportion of the surface area covered by impervious materials or lawns.

The "Percent Impervious as a Function of Zoning" spreadsheet in **Table 3-6** may also be used as a guideline for computing "C" factors to be used as a function of zoning type. This method would be applicable to watershed studies when approved by the County. Most designs should implement the values shown in Table 3-6.

For the purpose of sizing storm drain systems, green roofs and porous pavement will be considered impervious. These measures are typically designed to capture and treat runoff from relatively small storm events (i.e. 2-year storm). Once volume to be treated is intercepted, these systems typically contribute to direct runoff. Storm drain systems are designed for the 10-yr design storm event; therefore, no credits or reductions in the size of storm drain systems are provided for water quality control measures.

Table 3-5 – Runoff Coefficients

Area Description	County Zoning <sup>A</sup>	Green Area <sup>A</sup>	Avg. % Imp. <sup>B</sup>	HSG - A			HSG - B			HSG - C			HSG - D		
				0-2%	2-07%	>7%	0-2%	2-07%	>7%	0-2%	2-07%	>7%	0-2%	2-07%	>7%
Residential															
Single-Family (2 acre)	RE-2	--	12	0.23	0.26	0.29	0.24	0.27	0.32	0.27	0.30	0.35	0.30	0.33	0.39
Single-Family (1 acre)	RE-1	--	20	0.28	0.31	0.34	0.29	0.32	0.37	0.32	0.35	0.40	0.35	0.38	0.44
Single-Family (3/5 acre)	RE-2C	--	25	0.31	0.34	0.37	0.32	0.35	0.40	0.35	0.38	0.43	0.38	0.41	0.47
Single-Family (1/2 acre)	R-200	--	25	0.31	0.34	0.37	0.32	0.35	0.40	0.35	0.38	0.43	0.38	0.41	0.47
Single-Family (1/3 acre)	R-150	--	30	0.35	0.38	0.41	0.36	0.39	0.44	0.39	0.42	0.47	0.42	0.45	0.51
Single-Family (1/5 acre)	R-90	--	38	0.40	0.43	0.46	0.41	0.44	0.49	0.44	0.47	0.52	0.47	0.50	0.56
Single-Family (1/8 acre)	R-60	--	65	0.57	0.60	0.63	0.58	0.61	0.66	0.61	0.64	0.69	0.64	0.67	0.73
Single-Family (1/10 acre)	R-40	--	70	0.61	0.64	0.67	0.62	0.65	0.70	0.65	0.68	0.73	0.68	0.71	0.77
Townhouse	RT	50	--	0.48	0.51	0.54	0.49	0.52	0.57	0.52	0.55	0.60	0.55	0.58	0.64
Multi-Family, High Density	R-10	45	--	0.51	0.54	0.57	0.52	0.55	0.60	0.55	0.58	0.63	0.58	0.61	0.67
Multi-Family, Medium Density	R-20	47	--	0.49	0.52	0.55	0.50	0.53	0.58	0.53	0.56	0.61	0.56	0.59	0.65
Multi-Family, Low Density	R-30	53	--	0.46	0.49	0.52	0.47	0.50	0.55	0.50	0.53	0.58	0.53	0.56	0.62
Multi-Family, High Rise	R-H	50	--	0.48	0.51	0.54	0.49	0.52	0.57	0.52	0.55	0.60	0.55	0.58	0.64
Mobile Home Park	R-MH	30	--	0.61	0.64	0.67	0.62	0.65	0.70	0.65	0.68	0.73	0.68	0.71	0.77
County Inn Zone	C-INN	50	--	0.48	0.51	0.54	0.49	0.52	0.57	0.52	0.55	0.60	0.55	0.58	0.64
Industrial															
Light	I-1	10	--	0.74	0.77	0.80	0.75	0.78	0.83	0.78	0.81	0.86	0.81	0.84	0.90
Heavy	I-2	10	--	0.74	0.77	0.80	0.75	0.78	0.83	0.78	0.81	0.86	0.81	0.84	0.90
Technology and Business Park	I-3	15	--	0.70	0.73	0.76	0.71	0.74	0.79	0.74	0.77	0.82	0.77	0.80	0.86
Low Intensity	I-4	20	--	0.67	0.70	0.73	0.68	0.71	0.76	0.71	0.74	0.79	0.74	0.77	0.83

Notes:

1. Engineer should use the HSG D soil when site is impacted with topsoil stripping or embankment placement.
2. Type A soils only used when off-site and within drainage area.

References:

- A. **County Zoning Code** and **Minimum Green Area** obtained from Montgomery County Zoning Codes.  
Not an all inclusive list (only common zones with minimum green area provided).
- B. Average impervious area obtained from **NRCS TR-55** for Comparable Cover types

Area Description	County Zoning <sup>A</sup>	Green Area <sup>A</sup>	Avg. % Imp. <sup>B</sup>	HSG - A			HSG - B			HSG - C			HSG - D		
				0-2%	2-07%	>7%	0-2%	2-07%	>7%	0-2%	2-07%	>7%	0-2%	2-07%	>7%
All other Zones or Development Areas must be computed using the following:															
Impervious	--	--	--	0.90	0.90	0.90	0.90	0.90	0.90	0.90	0.90	0.90	0.90	0.90	0.90
Unimproved Areas	--	--	--	0.50	0.55	0.65	0.50	0.55	0.65	0.50	0.55	0.65	0.50	0.55	0.65
Pervious Areas															
Open Space, Lawns, etc...	--	--	--	0.08	0.12	0.15	0.11	0.16	0.21	0.14	0.19	0.24	0.20	0.24	0.28
Lawns, sandy soil	--	--	--	0.05	0.10	0.15	0.10	0.15	0.20	---	---	---	---	---	---
Lawns, heavy soil	--	--	--	---	---	---	---	---	---	0.13	0.18	0.28	0.20	0.25	0.35
Pasture or Range	--	--	--	0.25	0.30	0.35	0.30	0.35	0.40	0.33	0.38	0.48	0.40	0.45	0.55
Meadow	--	--	--	0.20	0.25	0.30	0.25	0.30	0.35	0.28	0.33	0.43	0.35	0.40	0.45
Wooded	--	--	--	0.10	0.15	0.20	0.15	0.20	0.25	0.18	0.23	0.33	0.25	0.30	0.35
<i>Agriculture</i>															
Fallow (SR = straight Row)	--	--	--	0.68	0.73	0.78	0.73	0.78	0.83	0.76	0.81	0.91	0.83	0.88	0.93
Row Crops (SR)	--	--	--	0.56	0.61	0.66	0.61	0.66	0.71	0.64	0.69	0.79	0.71	0.76	0.81
Row Crops (Contoured)	--	--	--	0.46	0.51	0.56	0.51	0.56	0.61	0.54	0.59	0.69	0.61	0.66	0.71
Row Crops (Contoured & Terr.)	--	--	--	0.38	0.43	0.48	0.43	0.48	0.53	0.46	0.51	0.61	0.53	0.58	0.63
Small Grain (SR)	--	--	--	0.53	0.58	0.63	0.58	0.63	0.68	0.61	0.66	0.76	0.68	0.73	0.78
Small Grain (Contoured)	--	--	--	0.45	0.50	0.55	0.50	0.55	0.60	0.53	0.58	0.68	0.60	0.65	0.70
Small Grain (Contour & Terr.)	--	--	--	0.38	0.43	0.48	0.43	0.48	0.53	0.46	0.51	0.61	0.53	0.58	0.63
Rotation Meadow Seeded (SR)	--	--	--	0.45	0.50	0.55	0.50	0.55	0.60	0.53	0.58	0.68	0.60	0.65	0.70
Rotation Meadow Seeded (Contoured)	--	--	--	0.40	0.45	0.50	0.45	0.50	0.55	0.48	0.53	0.63	0.55	0.60	0.65
Rotation Meadow Seeded (Contour & Terr.)	--	--	--	0.34	0.39	0.44	0.39	0.44	0.49	0.42	0.47	0.57	0.49	0.54	0.59

Notes:

1. Engineer should use the HSG D soil when site is impacted with topsoil stripping or embankment placement.
2. Type A soils only used when off-site and within drainage area.

References:

- A. **County Zoning Code** and **Minimum Green Area** obtained from Montgomery County Zoning Codes.  
Not an all inclusive list (only common zones with minimum green area provided).
- B. Average impervious area obtained from **NRCS TR-55** for Comparable Cover Types

**3.2.3.2 Correction Factor**

A frequency-of-event correction factor, Cf, is used as a modifier to the Rational formula runoff coefficient. The intent of the correction factor is to compensate for the reduced effect of infiltration and other hydrologic abstractions during less frequent, higher intensity storms. The frequency-of-event correction factor, Cf, is multiplied by the runoff coefficient, C, to produce an adjusted runoff coefficient. Adjustment factors are tabulated by design storm below.

**Table 3-6 – Correction Factor**

<b>Design Storm</b>	<b>Correction Factor</b>
≤ 25-Years	1.00
25-Years	1.10
50-Years	1.20
100-Years	1.25

*(Table from HEC-22)*

**3.2.3.3 Rainfall Intensity**

Rainfall intensity, duration, and frequency (IDF) curves are necessary to use the Rational method. The IDF Curve Data for Montgomery County is shown in Table 3-8.

**Table 3-7 – Intensity.-.Duration - Frequency (IDF) Data**

<b>Time of Conc. (min.)</b>	<b>FREQUENCY</b>					
	<b>2 YR. (in/hr)</b>	<b>5 YR. (in/hr)</b>	<b>10 YR. (in/hr)</b>	<b>25 YR. (in/hr)</b>	<b>50 YR. (in/hr)</b>	<b>100 YR (in/hr)</b>
5	5.52	6.39	7.07	8.05	8.89	9.60
6	5.21	6.10	6.78	7.76	8.57	9.30
7	4.94	5.83	6.52	7.49	8.28	9.01
8	4.70	5.59	6.28	7.23	8.01	8.74
9	4.48	5.37	6.06	6.99	7.75	8.48
10	4.28	5.16	5.85	6.77	7.51	8.24
11	4.11	4.98	5.66.	6.56	7.28	8.01
12	3.95	4.80	5.48	6.37	7.07	7.79
13	3.80	4.64	5.31	6.18	6.87	7.58
14	3.67	4.50	5.15	6.01	6.68	7.39
15	3.54	4.36	5.00	5.84	6.50	7.20
16	3.43	4.23	4.86	5.68	6.33	7.02
17	3.32	4.11	4.73	5.54	6.16	6.85
18	3.22	3.99	4.60	5.40	6.01	6.68
19	3.13	3.89	4.48	5.26	5.86	6.52
20	3.04	3.78	4.37	5.13	5.72	6.37
21	2.96	3.69	4.26	5.01	5.59	6.23
22	2.88	3.60	4.16	4.90	5.46	6.09
23	2.81	3.51	4.06	4.79	5.34	5.96
24	2.74	3.43	3.97	4.68	5.22	5.83
25	2.67	3.36	3.88	4.58	5.11	5.71

**Montgomery County  
Department of Transportation**

---

Time of Conc. (min.)	FREQUENCY					
	2 YR. (in/hr)	5 YR. (in/hr)	10 YR. (in/hr)	25 YR. (in/hr)	50 YR. (in/hr)	100 YR (in/hr)
26	2.61	3.28	3.79	4.48	5.01	5.59
27	2.55	3.21	3.71	4.39	4.90	5.48
28	2.50	3.15	3.64	4.30	4.80	5.37
29	2.45	3.08	3.56	4.21	4.71	5.26
30	2.40	3.02	3.49	4.13	4.62	5.16
31	2.35	2.96	3.42	4.05	4.53	5.06
32	2.30	2.91	3.36	3.97	4.45	4.97
33	2.26	2.85	3.29	3.90	4.37	4.87
34	2.22	2.80	3.23	3.83	4.29	4.78
35	2.18	2.75	3.17	3.76	4.21	4.70
36	2.14	2.71	3.12	3.70	4.14	4.62
37	2.10	2.66	3.06	3.63	4.07	4.54
38	2.06	2.62	3.01	3.57	4.00	4.46
39	2.03	2.57	2.96	3.51	3.93	4.38
40	2.00	2.53	2.91	3.45	3.87	4.31
41	1.97	2.49	2.86	3.40	3.81	4.24
42	1.94	2.45	2.82	3.34	3.75	4.17
43	1.91	2.42	2.77	3.29	3.69	4.10
44	1.88	2.38	2.73	3.24	3.63	4.04
45	1.85	2.35	2.69	3.19	3.58	3.97
46	1.82	2.31	2.65	3.14	3.52	3.91
47	1.80	2.28	2.61	3.10	3.47	3.85
48	1.77	2.25	2.57	3.05	3.42	3.80
49	1.75	2.22	2.54	3.01	3.37	3.74
50	1.72	2.19	2.50	2.97	3.33	3.69
51	1.70	2.16	2.47	2.92	3.28	3.63
52	1.68	2.13	2.43	2.88	3.24	3.58
53	1.66	2.10	2.40	2.84	3.19	3.53
54	1.64	2.08	2.37	2.81	3.15	3.48
55	1.62	2.05	2.34	2.77	3.11	3.43
56	1.60	2.03	2.31	2.73	3.07	3.38
57	1.58	2.00	2.28	2.70	3.03	3.34
58	1.56	1.98	2.25	2.65	2.99	3.29
59	1.54	1.96	2.22	2.63	2.95	3.25
60	1.52	1.93	2.19	2.60	2.92	3.21

The Montgomery County rainfall data is based on the rainfall intensity data for Montgomery County MD (dated June 20, 1988).

### 3.2.4 NRCS Method

#### 3.2.4.1 General Information

The NRCS, formerly the Soil Conservation Service (SCS), peak flow method calculates peak flow as a function of drainage basin area, potential watershed storage, and the time of concentration. The graphical approach to this method can be found in TR-55. This rainfall-runoff relationship separates total rainfall into direct runoff, retention, and initial abstraction to yield the following equation for rainfall runoff:



$$Q_D = \frac{(P - 0.2S_R)^2}{(P + 0.8S_R)} \quad 3-10$$

Where:

- Q<sub>D</sub> = Depth of Direct Runoff (in)
- P = Depth of 24-hour precipitation (in) (Table 3-11)
- S<sub>R</sub> = Retention (in)

Empirical studies found that S<sub>R</sub> is related to soil type, land cover, and the antecedent moisture condition of the basin. These are represented by the runoff curve number, CN, which is used to estimate S<sub>R</sub> with the following equation:

$$S_R = Ku \left[ \left( \frac{1000}{CN} \right) - 10 \right] \quad 3-11$$

Where:

- CN = Curve Number (Table 3-8)[for multiple land use/soil types CN is weighted]
- Ku = Conversion Factor 1 (25.4 SI)

**Table 3-8 – NRCS Curve Numbers  
Runoff Curve Numbers for Urban Areas  
(Average Watershed Condition,  $I_a=0.2(S_R)$ )**

Land Use Description	% Impervious	Curve Numbers for Hydrologic Soil Group			
		A	B	C	D
Full developed urban areas (vegetation established)					
Lawns, open space, parks, golf courses, cemeteries, etc.					
Good condition; grass cover on 75% or more of the area		39	61	74	80
Fair condition; grass cover on 50 to 75% of the area		49	69	79	84
Poor condition; grass cover on 50% or less of the area		68	79	86	89
Paved parking lots, roofs, driveways, etc. (excl. right-of-way)					
Streets and roads		98	98	98	98
Paved with curbs and storm sewers (excl. right-of-way)		98	98	98	98
Gravel (incl. right-of-way)		76	85	89	91
Dirt (incl. right-of-way)		72	82	87	89
Paved with open ditches (incl. right-of-way)		83	89	92	93
Average Percent Impervious					
Commercial and Business Areas	85	89	92	94	95
Industrial Districts	72	81	88	91	93
Residential: Average Lot Size					
2 acre lots	12	46	65	77	82
1 acre lots	20	51	68	79	84
1/2 acre lots	25	54	70	80	85
1/3 acre lots	30	57	72	81	86
1/4 acre lots	38	61	75	83	87
1/8 acre lots or less (incl. Row Houses and Town Houses)	65	77	85	90	92
Developing Urban Areas (no vegetation established)					
Newly graded area		77	86	91	94
Cultivated agricultural Land					
Fallow					
Straight Row or Bare Soil		77	86	91	94
Conservation Tillage (Poor)		76	85	90	93
Conservation Tillage (Good)		74	83	88	90

The previous table assumes average antecedent moisture conditions. Soil maps are generally available through the local jurisdiction or the NRCS.

Peak flow is then estimated with the following equation:

$$q_p = q_u (A_k)(Q_D) \quad 3-12$$

Where:

- $q_p$  = Peak Flow (ft<sup>3</sup>/s)
- $q_u$  = Unit Peak Flow (ft<sup>3</sup>/s/mi<sup>2</sup>/in)
- $A_k$  = Basin Area (sq. mi.)
- $Q_D$  = Runoff Depth (in)

The unit peak flow is calculated with the following equation from the TR-55 manual in **Appendix F** (graphical depictions are also presented in TR- 55):

$$q_U = K_U \times 10^{C_0 + C_1 \log t_c + C_2 [\log(t_c)]^2} \quad 3-13$$

Where:

- $C_0, C_1, C_2$  = Coefficients as a function of the 24-hour rainfall distribution type and  $I_a/P$
- $t_c$  = Time of concentration
- $I_a$  = Initial Abstraction (in)
- $K_u = 1.0$  (0.000431)

**Table 3-9 – Coefficients for 24-hour Rainfall**

$I_a/P$	$C_0$	$C_1$	$C_2$
0.10	2.55323	-0.61512	-0.16403
0.30	2.46532	-0.62257	-0.11657
0.35	2.41896	-0.61594	-0.08820
0.40	2.36409	-0.59857	-0.05621
0.45	2.29238	-0.57005	-0.02281
0.50	2.20282	-0.51599	-0.01259

with:

$$I_A = 0.2(S_R) \quad 3-14$$

When ponding or swampy areas occur in a basin, considerable runoff may be retained in temporary storage. The peak flow should be reduced to reflect the storage with the following equation:

$$q_A = q_p \times F_p \quad 3-15$$

Where:

- $q_a$  = Adjusted Peak Flow (cfs)
- $F_p$  = Adjustment Factor

**Table 3-10 – Adjustment Factor (Fp) for pond and Swamp Areas**

Area of Pond or Swamp (%)	$F_p$
0.0	1.00
0.2	0.97
1.0	0.87
3.0	0.75
5.0	0.72

### 3.2.4.2 Rainfall Depths

The current rainfall depths for Montgomery County shall be used for all TR-55 and TR-20 analysis. The rainfall depths used for submission to other permitting agencies should comply with the requirements of those agencies. The current values are listed as follows:

**Table 3-11 – Storm Duration (24-hr Rainfall)**

<b>Storm Event (Years)</b>	<b>Rainfall Depth (in)</b>
1-Year	2.57
2-Year	3.10
5-Year	3.99
10-Year	4.77
25-Year	5.97
50-Year	7.03
100-Year	8.23

Data from NRCS WIN TR-55 model. (Supersedes TP-40 and 1981 MSHA Drainage Manual)
--

### 3.2.4.3 Limitations of NRCS Method

This NRCS method has a number of limitations which can have an impact on the accuracy of estimated peak flows:

- Drainage Area & Curve Number
  - Basin should have one main channel or branches with nearly equal times of concentration
  - Drainage areas of individual sub areas must be a factor of 5 or less
  - Curve Numbers must describe the average conditions used in design
  - Curve number equation does not account for rainfall duration or intensity
  - Basin should have fairly homogeneous CN values (i.e. Land use soils and cover are distributed uniformly throughout the watershed)
  - CN shall be 40 or greater
  - CN Procedure is less accurate when runoff is less than 0.5 inches
- Time of Concentration
  - $t_c$  should be between 0.1 and 10 hr
  - Kinematic Wave solution for  $T_c$  should have sheet flow length of less than 300 feet
  - $T_c$  method must be the same for pre-development and post-development conditions
- Initial Abstraction Limitations
  - $I_a/P$  should be between 0.1 and 0.5
  - $I_a = 0.2S$  is based on agricultural watersheds (Urbanized watersheds differ)
- Other Limitations
  - Neither channel nor reservoir routing can be incorporated
  - $F_p$  factor is applied only for ponds and swamps that are not in the  $t_c$  flow path
  - Runoff from snowmelt or rain on Frozen ground cannot be estimated
  - Method applies only to surface runoff (beware large sources of subsurface flows or high groundwater levels in HSG A soils and forested areas with low CN values)
  - In watersheds with storm drains carefully identify the appropriate flow path (Large storms are typically not contained in the system)

### **3.3 Hydrograph Methods**

The design of storm drain systems requires the peak runoff from specified drainage areas. The peak runoff is based on land use or land cover for the ultimate conditions at a site. The following methods are to be used based on the size and complexity of the watershed being analyzed for design.

#### **3.3.1 TR-55 Method**

##### **3.3.1.1 General**

The NRCS TR-55 Tabular Hydrograph Method is a simplified procedure based on TR-20. It was created to avoid the computer calculations for TR-20 in the 1980's. TR-20 was run several times for many different watersheds to create a set of representative tables. It can be used to create partial composite hydrographs at any point in a watershed by dividing it into homogeneous sub-areas. The designer should refer to the Technical Release 55 User's Manual, Urban Hydrology for Small Watersheds (NRCS, 1986), for detailed guidance.

While documentation for WinTR-55 allows use of the method for areas up to 25 square miles, Montgomery County limits use of the method to 100 acres. This area limitation minimizes the assumptions of the designers and allows easier definition of homogenous sub-areas.

##### **3.3.1.2 TR-55 Method Constraints**

When using TR-55 in Montgomery County, the rainfall is a Type II rainfall distribution. With this method, it is important to understand that there is a difference between time of concentration and travel time.

- Travel time (Tt) is the time it takes for water to get from one location to another
- Time of concentration (Tc) is the time of travel from the hydraulically most distant point in the watershed to the point of interest (POI)

Time of concentration is the summation of the travel time within a watershed that consists primarily of overland flow, shallow concentrated flow, and channel/pipe flow.

#### **3.3.2 TR-20 Method**

##### **3.3.2.1 General**

The NRCS Unit Hydrograph Method is a detailed procedure for large, complex, non-homogeneous watersheds which involve calculations that require the use of computer programs such as the Hydrologic Modeling System (HEC-HMS developed by the U.S. Army Corps of Engineers' Hydrologic Engineering Center, HEC), and Technical Release No.20 (TR-20 developed by the U.S. Department of Agriculture's NRCS). The designer should refer to the NRCS National Engineering Handbook, Part 630 Hydrology for detailed guidance. TR-20 is suitable for modeling watersheds that range from 5 acres to 2,000 acres.

##### **3.3.2.2 TR-20 Method Constraints**

The NRCS Unit Hydrograph Method developed by the NRCS requires the same basic data as the Rational Method: drainage area, a runoff factor, time of concentration and rainfall. The NRCS approach is more sophisticated in that it also considers the time distribution of the rainfall, the initial rainfall losses to interception, depression storage and an infiltration rate that decreases during the course of a storm. With this method the direct runoff can be calculated for any storm, either real or synthetic, by subtracting infiltration and other losses from the rainfall to obtain the precipitation excess. Differences in Tt and Tc are discussed in Section 3.4.1.2. Details of the methodology can be found in the NRCS National Engineering Handbook, Part 630 Hydrology.

### **3.4 GIS Hydro 2000**

GIS Hydro 2000 is an ArcView GIS-Based application for conducting hydrologic analysis in the State of Maryland. The program is sponsored by the Maryland State Highway Administration. GIS Hydro 2000 integrates a complete database of terrain, land-use, and soils data with tools for assembling and evaluating hydrologic models including regional regression equations and TR-20. The program is designed to support the procedures for hydrologic analysis recommended by the Maryland Hydrologic Panel. GIS Hydro is intended to be used to analyze large drainage areas of over 400 acres where bridges and large culverts (typically box or arch) are proposed to cross perennial streams and rivers.

Since GIS Hydro is continually evolving, use of the software for project development shall be utilized on a case by case basis. Use of GIS Hydro must be approved by the appropriate agencies prior to use on final design of projects; however, GIS Hydro may be used for conceptual and planning studies.

### **3.5 Concurrent Flood Analysis**

Typically, a concurrent flood analysis is performed when there is a confluence of two watercourses. These confluences can include stream junctions or locations where a culvert or storm drain system discharges into a larger waterway. Concurrent flooding should be evaluated on a case by case basis so that ditches, channels, storm drains, and culverts are not oversized or undersized; thereby, increasing cost or the risk of flooding.

The main stream area is considered to be the stream with the larger drainage area; whereas, the tributary is storm conveyance with the smaller drainage area. The study point may be either on the main stream or tributary when using a concurrent flood analysis. The area ratio in Table 3-12 is the ratio of the drainage areas for the Main Stream and tributary.

Once the drainage areas have been assessed and an area ratio determined (See Table 3-13), the designer shall round the calculated ratio down and develop the appropriate discharges to complete the analysis.

**Table 3-12 – Concurrent Flood Ratios**

Area Ratio	10-Year Design		100-Year Design	
	Main Stream	Tributary	Main Stream	Tributary
10,000:1	1	10	2	100
	10	1	100	2
1,000:1	2	10	10	100
	10	2	100	10
100:1	5	10	25	100
	10	5	100	25
10:1	10	10	50	100
	10	10	100	50
1:1	10	10	100	100
	10	10	100	100

*Note : Table from AASHTO Model Drainage Manual*

### 3.6 Bankfull Discharge Estimates

Estimation of bankfull discharge and bankfull dimensions are necessary for design of natural channels and may be necessary for sub-channels located at bridges or open bottom culverts. Due to development within watersheds, bankfull dimensions should be obtained from field measurements and observations; however, approximation of bankfull dimensions by mathematical formulas can prove beneficial prior to identifying the bankfull dimensions in the field. Bankfull discharge roughly translates to a rainfall event of approximately 1.5- to 2 –years.

Bankfull discharges can be approximated using the “Maryland Stream Survey: Bankfull discharge and Channel Characteristics of Streams in the Piedmont Hydrologic Region” CBFO S02-01 (Dated March 2002) U.S. Fish & Wildlife Service.

$$Q_{BKF} = 84.59(DA)^{0.76} \quad 3-16$$
$$A_{BKF} = 17.42(DA)^{0.73} \quad 3-17$$
$$W_{BKF} = 14.78(DA)^{0.39} \quad 3-18$$
$$D_{BKF} = 1.18(DA)^{0.34} \quad 3-19$$

Where:

- DA = Drainage Area (sq. mi.)
- Q<sub>BKF</sub> = Bankfull Discharge (cfs)
- A<sub>BKF</sub> = Bankfull Cross Sectional Area (ft<sup>2</sup>)
- W<sub>BKF</sub> = Bankfull Width (ft)
- D<sub>BKF</sub> = Bankfull Depth (ft)

Use of the bankfull equations is not a substitute for field identification of the bankfull dimensions. The bankfull dimensions can vary from site to site depending on topography and development. Upon identifying the bankfull dimensions in the field, a more accurately defined bankfull discharge should be developed for sub-channel and channel designs required by the project and the site conditions.

Designers utilizing stream restoration/stabilization techniques must have adequate training or guidance from senior staff to complete bankfull channel designs. These designs are often required as part of the permitting process for storm drain outfalls, culverts, and/or bridges on Waters of the State or Waters of the United States.

## 4 HYDRAULIC DESIGN

### 4.1 General

While hydraulic design of storm drain systems varies from site to site for various projects, the design engineer shall be cognizant of on-site and off-site conditions that may impact the hydraulic aspects of the project. Pavement storm drain systems for Montgomery County shall be designed to convey the design (10-year) storm discharge on the basis of the ultimate development of the tributary watershed. Culvert and through systems shall be designed for the design storm listed in Section 3.

Storm drain systems, within pipes or culverts, shall extend across the entire project or subdivision to the limits of right-of-way, easement(s), or property line(s). In order to facilitate Environmental Site Design (ESD), storm drain systems are not required to be enclosed (piped) throughout the entire site; however, the overall storm drain system (including ditches) must be designed to convey the ultimate design storm discharge through the project / site without surcharging the system. Storm drain systems shall be designed to minimize potential for flooding of any structure by a base flood storm event unless located in an existing floodplain.

In subdivisions without sanitary sewers, the storm drain pipe must extend 50 feet beyond the existing or approved septic field (unless otherwise approved by Montgomery County). Storm drains will not be required to extend across the entire subdivision. Once beyond the 50 foot limit, the storm drain pipe may be discharged into a ditch to the point where the storm drain system leaves the subdivision. In cases where the 50 foot storm drain extension crosses a property line, an easement must be provided for the storm drain system. In cases where the ditch crosses several properties within 50 feet of multiple septic fields, relocation of the ditch/channel may be considered in lieu of the closed storm drain system.

#### 4.1.1 On-site and Off-site Considerations

During the design of storm drain systems, the County recommends that the design engineer perform a site visit to document the existing conditions at the site prior to development. Site visits aid in identifying conditions that may impact the hydraulics or the placement of proposed systems. The items contained in the Table 4-1 should be considered when performing a site inspection; however, the table is to be used as a guide (starting point) and not meant to be an all-inclusive list of items to be identified. Site conditions vary widely from site to site throughout the County.

**Table 4-1 – Site Considerations**

<b>On-Site Considerations</b>	<b>Off-Site Considerations</b>
Underground Utilities	Backwater Conditions
Public (water, gas, sewer, etc...)	Downstream Culvert
Private (Septic systems, well heads, etc...)	Large River or Pond
Steep or very flat slopes	Tidal Influences
Existing and proposed sump points	Ditch or Channel Restrictions
Verify existence/size of existing storm sewers	Large amounts of debris in channels
Soils (bedrock vs. sand/clay)	Future Development (Use Zoning as a guide)



## 4.2 Pavement Drainage

The design requirements for pavement drainage described within this section are for the peak discharge of the 10-year design storm, unless noted otherwise.

### 4.2.1 Street Capacity (Spread)

The spread is recommended to be computed considering the cross section through the gutter pan to equal the cross slope of the street paving. When approved by MCDOT, the gutter may be analyzed as a composite gutter where the gutter type does not vary significantly throughout the length of the project. Refer to the appropriate curb and gutter detail as dictated by the Context Sensitive Road Design Standards for gutter geometry. Spread criteria shall be as follows:

- Primary and higher roadway: the spread shall not exceed 8 feet.
- Tertiary and secondary roadway: water shall not cross the centerline and may not exceed 13 feet.

The use of FHWA Hydraulic Engineering Circular No. 22, "Urban Drainage Design Manual" (HEC-22), is recommended for design uniform gutters from which the following equations are taken:

$$Q = \frac{0.56}{n} S_x^{5/3} S^{1/2} T^{8/3} \quad 4-1$$

and

$$d = T(S_x) \quad 4-2$$

Where:

- Q = Flow Rate in Gutter (cfs)
- S<sub>x</sub> = Cross Slope of the Roadway (ft/ft)
- S = Longitudinal Gutter Slope (ft/ft)
- T = Top Width of Flow or Spread (ft)
- d = Depth of Flow in the Gutter at the Flowline (ft)
- n = Manning's 'n' (Appendix B)

**Table 4-2 – MCDOT & MSHA Gutter Widths and Cross Slopes**

MCDOT/MSHA Standard No.	Gutter Type	Gutter Width (in)	Gutter Depth (in)	Gutter Cross Slope (ft/ft)
<b>MCDOT</b>				
MC-101.01	Type A	16.00	1.50	0.0938
MC-101.02	Type C	9.63	0.88	0.0909
MC-101.03	Type F	13.50	1.25	0.0926
<b>MSHA</b>				
MD-620.02	Type A	12.00	0.50	0.0417
MD-620.02	Type B	12.00	0.50	0.0417
MD-620.02-01	Type C	12.00	0.50	0.0417
MD-620.02-01	Type D	12.00	0.50	0.0417

\* Verify with current standard details / project details

The MCDOT and MSHA gutters are composite gutters, due to the complexity of spread analysis;

designers should follow the methods outlined in the most current version of the HEC-22 Manual.

## **4.2.2 Inlet Spacing, Size and Capacity**

### **4.2.2.1 General Policy**

Curb opening inlets shall be used for all roadways which require curb and gutter as a part of the standard roadway section. Unless otherwise approved by MCDPS or MCDOT, no grate only inlets shall be used within the County system.

Flanking inlets shall be used at all sump conditions where clogging of a single sump inlet could cause flooding of structures or unsafe conditions on main streets. The minimum length of a curb opening inlet in a sump shall be 10 feet. Curb and gutter at low points or sump conditions along the profile grade of the roadway shall utilize curb opening inlets with a minimum opening of 10-feet. Therefore, a MC Standard MC-501.01 Type "A-10" Inlet would be considered the minimum opening. For all sag or sump conditions, the 100-year storm overflow shall be contained within a surface drainage easement. If a surface drainage easement is not attainable, ensure that the resulting 100-year overflow does not impact more property than would be impacted under existing conditions. Where flood conditions on private property existed prior to development, the designer will consult with MCDOT and MCDPS to determine the most appropriate course of action for the site.

Inlets shall not be placed in cross walks or impede pedestrian movement. Care should be exercised when placing inlets near pedestrian ramps in curb sections. Inlets shall be placed outside the transition slope for the pedestrian ramp.

### **4.2.2.2 Inlet Locations and Spacing**

Gutter inlets shall be placed at a minimum of the following locations:

- In all sags (flanking inlets where required to prevent flooding of property or buildings)
- Upgrade of all intersections and driveways (except where flow is less than 3 cfs)
- Any point along streets where
  - Spread greater than 8 feet would occur
  - Interception would be less than 70%
  - Bypass would exceed 3 cfs
- Inlets at intersections shall be located with the closest end of the inlet at least 3 feet from the Point of Curvature (P.C.) of the curb fillet.
- Inlets at pedestrian ramps shall be located with the closest end of the inlet at least 3 feet from point where the ramp connects to the top of curb.

Roadway longitudinal ditch inlets shall be placed at a minimum of the following locations:

- In all sumps or ditch termination points
- Where the design storm ditch flow depth exceeds 1 foot in depth
- Where freeboard for a ditch is less than 0.5 feet
- Where the 100-year design storm breaches the drainage easement.

For yard inlets between houses, see Residential Lot Drainage Requirements

**4.2.2.3 Inlet Computations**

Computations shall be provided for all inlets within or that affect the County storm drain system. See Table 4-4 for Montgomery County Standard inlets. The MCDOT standard form in **Appendix D** may be used for inlet computations.

**Table 4-3 – MCDOT Standard Inlets**

MCDOT Standard No.	Inlet Type	Inlet Style
MC-501.01	Type A	COS - Curb Opening (Center Access)
MC-502.01	Type B	COG -Curb Opening
MC-502.02	Type B (Rev.)	COG -Curb Opening (Reverse)
MC-503.01	Type D	Terminal Inlet
MC-504.01	Type E	Ditch Inlet
MC-505.01	Type E-4	Ditch Inlet
MC-506.01	Type J	Ditch Inlet
MC-506.02	Type J	Ditch Inlet - Terminus

The following equations may be used to size curb-opening inlets on a continuous grade:

The length of curb-opening inlet required for total interception of gutter flow on a pavement section with a straight cross slope is expressed by the following equation:

$$L_T = 0.6Q^{0.42} S^{0.3} \left( \frac{1}{n(S_x)} \right)^{0.6} \tag{4-3}$$

Where:

- $L_T$  = Curb Opening Length required to Intercept 100% of Flow (ft)
- $S_x$  = Cross Slope of the Roadway (ft/ft)
- $S$  = Longitudinal Gutter Slope (ft/ft)
- $n$  = Manning's Roughness Coefficient (See Appendix B)
- $Q$  = Design Discharge (cfs)

**Composite Gutter and Curb Opening Inlet Interceptions**

Where composite gutters are used, the designer will follow the methods outlined in HEC-22. The gutter spread and inlet interception (for all inlet types) is a function of the equivalent slope ( $S_w$ ) for the inlet. Due to the difficulty of computation and iterative process, the designer is encouraged to utilize FHWA or MCDOT approved software to complete the analysis. The required length and efficiency of an inlet within a depressed gutter section can be found by evaluating the equivalent gutter slope  $S_w$  in the above equation, where:

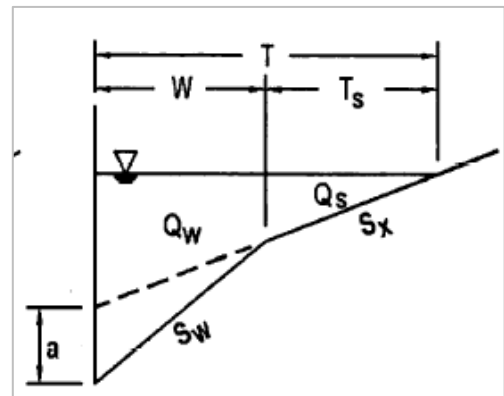

$$S_w = S_x + a/W$$

4-4

Where:

- $S_w$  = Cross slope of the gutter measured from the cross slope of the pavement,  $S_x$
- $a$  = gutter depression (in)
- $W$  = gutter width (in)
- $E_o$  = Efficiency =  $Q_w/Q$  ratio of flow in the depressed section to total gutter flow
- $Q_w$  =  $Q - Q_s$  flow in the depressed section (cfs)
- $Q_s$  = Flow in the Road (cfs)
- $Q$  =  $Q_s/(1-E_o)$  total gutter flow (cfs)
- $T$  = Top width of flow/Spread (ft)
- $T_s$  = Top width of flow/Spread on pavement slope (ft)

Notes:

- The Engineer must determine the local gutter depression at the inlet throat for each inlet
- $Q_w$  must be computed algebraically in the equation above rather than read from charts in Chapter 4, FHWA Hydraulic Engineering Circular No. 22
- Designer may use FHWA supported software Visual Urban (or equivalent when approved by MCDOT).

### **Inlet Efficiency**

The efficiency of curb-opening inlets shorter than the length required for total interception is expressed by the following equation:

$$E = 1 - \left( 1 - \frac{L}{L_T} \right)^{1.8}$$

4-5

Where:

- $E$  = Efficiency of the Curb Opening
- $L$  = Curb Opening Length (ft)
- $L_T$  = Curb opening length required to intercept 100% of the gutter flow, (ft)

The equation shown is for simple gutter computations. When composite gutters are utilized, the designer should utilize the methods outlined in the HEC-22 Manual or MCDOT approved software to complete the analysis.

### **Sump Inlet Spread**

Sump inlets shall be designed to pick up 100 percent of the (design) storm while maintaining a roadway spread of no more than 8-ft. The length of a curb opening inlet in a sump is determined by the following relationship:

$$Q = 3.0Ld^{1.5}$$

4-6

Where:

- Q = Flow to the Inlet (cfs)
- L = Length of the inlet throat (ft)
- d = Depth of water ponding at the inlet (ft)

This equation only applies to simple gutter curb opening inlets under weir flow conditions. Analysis of weir flow or orifice flow at composite gutter sections should be analyzed using HEC-22 methodology. If the curb opening becomes fully submerged, the orifice equation from HEC-22 shall be employed. To determine the ponding depth at the inlet (d), the designer should consider both the allowable roadway spread as well as the height of the curb section.

Sump yard inlets shall be designed to capture 100 percent of the design storm while maintaining a ponding depth of not more than 1-ft and a freeboard of 0.5 feet or more within the ditch. For weir type inlet openings, Equation 4-7 may be used to determine the ponding depth.

Computations shall be provided for all inlets within or that affect the County system. The MCDPS standard form may be used for inlet computations.

The use of FHWA Hydraulic Engineering Circular No. 22, "Urban Drainage Design Manual" (HEC-22), is recommended for sizing all other inlet types.

### 4.2.3 Grates

Grate type inlets should be used only when design considerations preclude the use of MC Standard curb opening inlets or when required by regulation. Grate inlets when placed within the clear zone or potential path of a bicycle shall utilize a bicycle safe grate that is HS-20 loading compliant. The bicycle safe grate requirement will be waived only on a case-by-case basis where it is determined that the inlet would not pose a hazard to bicyclists. Applicable styles of bicycle safe grates are as follows:

- Reticulated
- Curved Vane
- Parallel Bar Grate

**Figure 4-1 – Bicycle Safe Grate Options**

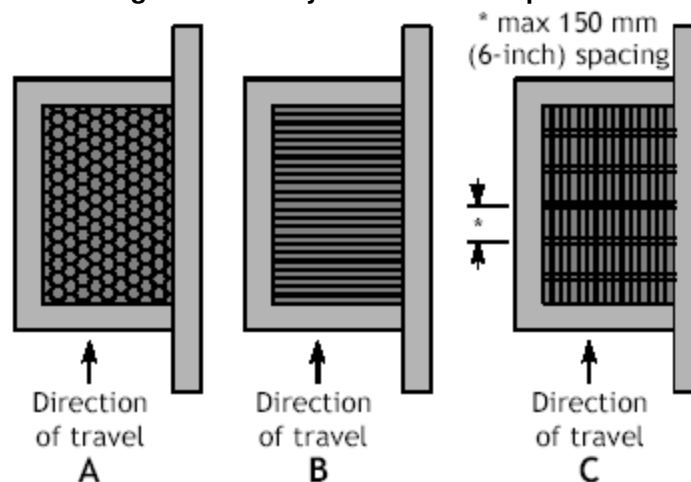

Source: Oregon Bicycle and Pedestrian Plan<sup>(1)</sup>

All grate inlets, unless otherwise approved by the County, shall utilize combination curb openings to act as a sweeper and prevent clogging of the inlets.

Grates in crosswalks and walkways shall be avoided where practicable; however, ADA specifications shall be met for inlets located within walkways.

While MC curb opening inlets are bicycle safe, they do not have a grate and are not applicable to this section. Based on a review of the MCDOT and MSHA grates, the grates that meet the bicycle safe options are included in Table 4-4. When grates are approved for use, the designer shall review the following grates for applicability and use on the project.

**Table 4-4 – MCDOT & MSHA GRATES**

Category	Standard Number	Inlet Type	Description
Reticulated	MD 374.02	---	Standard WR & WRM Inlet
Reticulated	MD 374.12	---	Standard NR & NRM Inlet
ADA	MD 374.85-01	---	Standard "ADA" Compliant Single Inlet
ADA	MD 374.86-01	---	Standard "ADA" Compliant Double Inlet
Curved Vane	MD 376.12-01	E-CV	Curved Vane Grate
Curved Vane	MD 379.02-01	S-CV	Curved Vane Grate Single
Curved Vane	MD 379.05-01	S2-CV	Curved Vane Grate Tandem
Reticulated	MD 379.08	---	Type S - Reticular replacement Grate

*Note: Review MSHA Book of Standards for Highway & Incidental Structures before use*

#### 4.2.4 Manholes, Inlets, and Field Connections

- 1) For County storm drain systems, MCDOT standard structures shall be utilized for the project. Structure selection shall fit the site requirements. Where MCDOT standards do not apply, applicable MSHA inlets or WSSC Standard details should be used prior to design of special details for the site.
- 2) Access structures shall be spaced as shown in Table 4-5:

**Table 4-5 – Access Spacing**

Pipe Range	Access Spacing
15" through 24" Pipe	400' Maximum
27" through 42" Pipe	500' Maximum
≥ 48" Pipe	600' Maximum

*Other Lengths require special approval by MCDOT*

- a) A minimum slope of 1 percent or 0.1 ft. drop, whichever is greater, shall be provided through structure inverts.
- b) Through structures are to be provided with a shaped channel, with a rounded bottom conforming to the inlet and outlet pipe. The sidewalls of the shaped channel shall extend to the crowns of the pipes in the structure. Where branch lines enter structures at a considerable elevation above the bottom of the structure, the shaped channel in the structure may be required to have a special lining. Where the drop on the main line through a structure is greater than that which can be accommodated by a shaped channel with the invert on a 1.5 foot horizontal to 1 foot vertical slope, the bottom of the structure shall be lined with granite blocks at least 4 inches thick. No shaped channel will be required for this type of construction, but the bottom of the structure shall slope at least 1/2 inch per foot toward the invert of the outlet pipe.
- c) Field connections of branch lines into the mainline pipes may be used only where the main line pipe involved is 27 inches in diameter or larger. The branch line may be no

larger than two-thirds of the diameter of the main line pipe.

- d) Sufficient contours are to be shown around yard inlets to insure that positive drainage to the inlet is obtained. The limits of the area of inundation during the 10 and 100 year storms shall be shown on the plan and storm drain profile.
- e) Street inlets shall be a minimum of 3 feet from the P.C. of the curb fillets.
- f) Street inlets in sump areas shall be located at the low point of the street grade.
- g) "B" type inlets shall not be used in sump areas.
- h) All structures are to be numbered and listed in the structure schedule which shall include the following information:
  - Structure type
  - Agency (MCDOT,MSHA) and standard number
  - Station and location
  - Structure data: size, top elevation, invert(s), slot elevation
  - Structure modification notes
  - Pre-cast structure standard number and supplier

Separate structure schedules will be shown for County and private systems.

- 1) In general, private drains are to be connected to a County inlet or manhole.
  - a) In residential areas, a maximum concentrated flow of 3 cfs will be allowed to cross into the County right of way from off-site.
  - b) Inlets and Manholes shall not exceed 12-ft in depth unless approved by MCDPS or MCDOT. For deeper structures, special design may be necessary and must provide safe landing areas and step ladders with cage protection around the ladder.

### **4.3 Storm Drain Design**

The design requirements for pavement drainage described within this section are for the peak discharge for the 10-yr design storm as determined using the guidelines in Section 3. If storm water management (SWM) is used upstream of the drainage system, analyze the designed system with and without the SWM measure. The analysis without the SWM is for information only in the event that that SWM features are not adequately maintained.

#### **4.3.1 Determination of Conveyance Size**

All closed systems shall be designed so that the 10-yr hydraulic grade line (HGL) is no higher than 1 foot above the crown of the pipe and at least one foot below the top of any inlet grate or manhole cover. Where non-pressurized pipes are present, Manning's formula is to be used to correlate velocity, slope, and friction for determining the size of storm drain required to convey the calculated design flow under non-pressurized conditions. To ensure non-pressurized conditions for pipe flow, the hydraulic gradient must be below the crown of the inlet pipe for the design storm. Additional information is provided in section 4.3.2. The MCDOT standard form may be used for pipe computations.

The roughness coefficients to be used are shown in the Appendix B.

While it is true helical corrugated metal pipe may have a lower 'n' value than annular corrugated metal pipe, care should be exercised in the use of the reduced values. Since the low 'n' values depend upon the development of spiral flow across the entire cross-section of the pipe, the Design Engineer must verify that fully developed spiral flow can occur in the design situation.

The 'n' values for annular pipe shall be used in place of those for helical pipe under the following conditions for which spiral flow cannot be achieved:

- Partial flow in the pipe

- Extremely high sediment load
- Short culverts less than 20 times the diameter of the culvert in length
- Non-circular pipes

When drains are composed of more than one of the above mentioned materials, a composite roughness coefficient must be determined in proportion to the wetted perimeter of the different materials.



### 4.3.2 Hydraulic Gradient

The hydraulic gradient shall be computed for the 10-year design storm for all pipe sizes and shall take into consideration friction losses in the pipes and losses in the structures caused by differences in velocity, change in direction of flow, incoming volume, entrance, exit and other applicable conditions. All closed systems shall be designed so that the 10-yr hydraulic grade line (HGL) is no higher than 1 foot above the crown of the pipe and at least one foot below the top of any inlet grate or manhole cover. The process for determining the hydraulic gradient throughout the drainage system is provided below.

Figure 4-2 - Hydraulic Grade Line

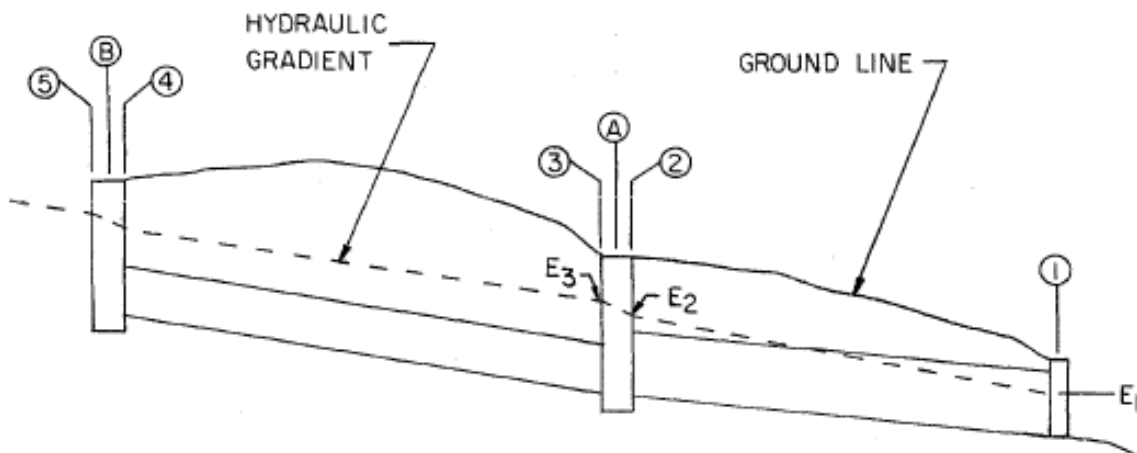

#### 4.3.2.1 Beginning Evaluation

Starting hydraulic gradient elevations must be determined at outlets. The existing and proposed 10 and 100 year water surface elevations must be shown and computations for the design storm provided at all outlets into swales, streams and storm water management ponds. At free outfalls, where the pipe discharges without tail water effects, the starting hydraulic gradient elevation will begin at the crown of the outfall pipe. Where a storm drain system connects to a storm water management facility, tail water conditions for the pipe design storm must be analyzed using the water surface elevation of the same design storm for the storm water management facility.

If the designed system is to outfall to an existing system, the hydraulic gradient for the receiving system must be calculated by the guidelines within this section and used as the starting point at the junction of the two systems. If the determination of the receiving system's hydraulic gradient is not possible or infeasible, the highest possible flooding elevation of the downstream system should be used. (i.e. the top of embankment of a pond or the elevation of the top of the receiving pipe systems nearest drainage structure).

Once the beginning hydraulic gradient elevation is determined, add the head losses through the system moving from downstream to upstream as detailed below. The beginning hydraulic gradient elevation corresponds to "E1" in **Figure 4-2**.

#### 4.3.2.2 Pipe Losses

Compute pipe losses throughout the drainage system as outlined in Chapter 7 in the FHWA HEC-22 Urban Drainage Design Manual. Add the calculated head loss due to the friction loss in the pipe to the downstream hydraulic gradient elevation. The resulting elevation corresponds to "E2" in **Figure 4-2**.

$$H_f = S_f (L) \quad 4-7$$

$$S_f = \frac{H_f}{L} = \left( \frac{Q(n)}{K_Q (D)^{2.67}} \right)^2 \quad 4-9$$

Where:

- Hf = Headloss (ft)
- Sf = Friction Slope (ft/ft)
- L = Length of Pipe (ft)
- Q = Discharge (cfs)
- n= Manning's Coefficient (See Appendix B)
- Kq = Constant 1.49
- D = Pipe Diameter (ft)

#### 4.3.2.3 Manhole, Inlet and Field Connection Energy Losses

Head losses through the storm drain system should be computed using the methodologies outlined in the MSHA Highway Drainage Manual – Storm Drain Chapter (for additional direction, the designer may also refer to the FHWA's HEC-22 Urban Drainage Design Manual). The designer should calculate the losses for the following conditions that may exist within a storm drain system.

- a) Inlet Losses
- b) Access Hole (manhole) Losses
- c) Bend Structure
- d) Junctions
- e) Transition Losses
- f) Field Connections

##### **Inlet, Access Hole, and Bend Structure Losses**

The formula for head losses associated with Inlets, Access Holes, and Bend Structures are summarized as follows:

$$H_b = K_b \left( \frac{V_f^2}{2g} \right) \quad 4-8$$

Where:

Hb = Headloss (ft)

Kb = Headloss Coefficient {See Table in Appendix B}

Vf = Frictional velocity in the outlet pipe (fps) {Velocity for given q and d=ho}

g = Acceleration due to gravity(fpsps)

### Junctions

The 10-year discharge shall be used for incoming and outlet pipes in junctions. The controlling angle determines the amount of head loss applied to the junction.

**Figure 4-3 – Head loss through a Junction**

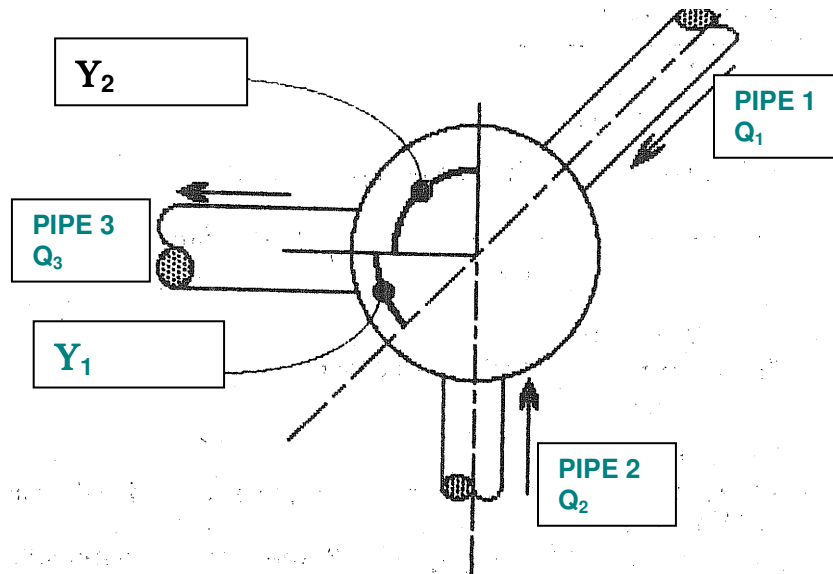

The procedure for junctions is summarized as follows:

1. Determine  $V_{1/3}$  the friction velocity of  $Q_1$  in Pipe 3 (Equation 3-6)
2. Determine  $V_{2/3}$  the friction velocity of  $Q_2$  in Pipe 3 (Equation 3-6)
3. With  $V_{1/3}$  and  $v_1$  determine the structure loss  $L_{v1}$  (Equation 4-8 and Appendix B for  $K_b$  values)
4. With  $V_{2/3}$  and  $v_2$  determine the structure loss  $L_{v2}$  (Equation 4-8 and Appendix B for  $K_b$  values)
5. If  $L_{v1}$  is greater,  $v_2$  is the controlling angle  $v_c$
6. If  $L_{v2}$  is greater,  $v_1$  is the controlling angle  $v_c$

The controlling angle is used to calculate the loss in that structure. Determine the friction velocity of  $Q_3$  in pipe 3 and use  $v_c$  to determine  $H_b$ , the head loss at the junction.

### **Transition Losses**

In instances where pipes must be connected to smaller or larger existing pipes the head loss for the pipe can be calculated using the transition loss equations in Chapter 7 of FHWA Hydraulic Engineering Circular No. 22.

### Field Connections

**Figure 4-4 - Head Loss Through a Field Connection**

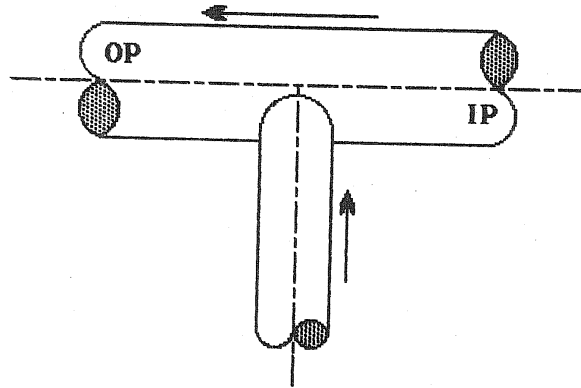

The structure loss at a field connection is the same as that for a manhole.

### **4.3.3 Pipe Design Requirements**

- 1) Pipe under Pavement (all conditions except for driveway pipes):
  - a) Reinforced concrete and high density polyethylene pipe shall be used in storm drains for cross pipes and longitudinal pipes under pavement unless otherwise approved by Montgomery County.
  - b) Reinforced concrete pipe and high density polyethylene can be used under driveway pavements.
  - c) Reinforced concrete pipe and high density polyethylene may be used for large culverts that will not become a part of an ultimate enclosed system.
  - d) Corrugated metal pipe is not recommended due to lifespan and maintenance concerns.
- 2) Pipes not under Pavement (within medians, swales, or grassed areas):
  - a) Reinforced concrete pipe and high density polyethylene can be used throughout the limits of the system that is not directly beneath pavement.
  - b) Reinforced concrete pipe may be used for culverts greater than 36-inch that will not become a part of an ultimate enclosed system as well as driveway apron culverts.
  - c) Where approved by MCDPS or MCDOT, High Density Polyethylene (HDPE) pipe may be used provided it meets the following criteria:
    - The maximum size for HDPE is 36 inches in diameter.
    - The pipe must conform to current AASHTO standards.
    - Must be placed in trench bedding Class E, see Appendix C.
    - Must be shown on plans as HDPE. HDPE may not be substituted for other materials specified on plans.
    - Use of high density polyethylene end section, which will be exposed to extended sunlight, is not recommended.

- d) Reinforced concrete pipe, high density polyethylene, or corrugated metal pipe may be used at entrance and outlet structures (endwalls and end sections) where at least one end of the pipe can be accessed by a maintenance vehicle (e.g., within sodded easements).

**NOTE:** This is the only exception to the requirement for reinforced concrete pipe in an enclosed County drainage system.

- e) All privately maintained storm drains connecting to County storm drain structures are to be reinforced concrete pipe, corrugated metal pipe, high density polyethylene, or solid (rigid) PVC Pipe. No portion of the privately maintained structures shall extend beneath the paved roadway section.
- f) The minimum pipe size to be used within the County system shall be 15 inches in diameter for all pipes materials. Reinforced concrete pipe of 12 inches in diameter may be used, with a waiver from MCDPS or MCDOT, if site conditions will not permit a larger pipe. Alternate pipe size and material types must be pre-approved by the County and all pipe material throughout the system must be the same whenever possible.
- g) Inlet pipes shall be placed at a minimum of 90 degrees to the outlet pipe at all structures.
- h) Pipe class is to be in accordance with the MCDPS load charts, entitled "RCP Supporting Strengths" located in **Appendix C**. NOTE: The charts are intended for use with circular pipe only. For loading conditions beyond the limits and scope of the charts, the Design Engineer shall provide computations verifying the pipe class required for H-20 truckload or E-80 Cooper trainload.
- i) One foot minimum cover over the outside of the pipe is to be provided. A typical section shall be shown on the drawings.
- j) Pipes 27 inches or larger in diameter may be curved horizontally and/or vertically. The joint opening is not to exceed 1/3 the length of the tongue in horizontal and crest vertical curves, and is not to exceed 1/4 the length of the tongue in sag vertical curves. All pertinent pipe curve data is to be shown on the drawing, i.e., radius, chord, tangent, arc, P.C., P.T. and P.I. for horizontal curves and P.V.C., P.V.T., and the length of curve for vertical curves. Maximum laying length of pipe for each curve shall be shown.
- k) Pipe shall not be designed on a slope less than 0.5 percent. However, to enhance self-cleaning characteristics, 15 and 18 inch diameter pipe are to be designed on an actual slope of 1 percent or greater.
- l) Decrease in pipe size at structures will not be permitted for 21-inch and smaller pipes. The maximum decrease in pipe size shall be the next smallest standard size (e.g., 42-inch to 36-inch pipe). A manhole must be placed at any change in pipe size, even for proposed connection into an existing pipe.
- m) Downsizing of storm drain pipe to one size smaller is permitted only once in any proposed storm drain system. Where a larger pipe must discharge directly into a smaller pipe, the connection must allow for the bottom inverts to meet at the same elevation in order to prevent water from ponding within the pipe and to keep head losses at the transition to a minimum. A design waiver from MCDOT or MCDPS must be attained for this connection.
- n) Field connections of branch lines into the mainline pipes may be used only where the main line pipe involved is 27 inches in diameter or larger. The branch line may be no larger than two-thirds of the diameter of the main line pipe.
- o) Profiles of proposed storm drains shall indicate size, type and class of pipe, design grade and invert elevations at both ends of pipe run, Q10, Q10/A, and the minimum slope required for full flow in the pipe. The hydraulic grade line shall be shown on all pipe profiles. The actual flow velocities in pipe will be shown for all outlet pipes.

- p) Pipe elevations and grades shall be set to avoid hydrostatic surcharge during the design condition. Under special circumstances, when approved by MCDPS, head may be placed on these pipes. When the head on these pipes exceeds 1 foot, special treatment of the pipe joints will be required, e.g., rubber gasket joints or concrete collars.
- q) Storm drain outfall pipes shall not be placed below the normal water surface elevation of any pond unless approved by MCDOT or MCDPS.
- r) A pipe schedule tabulating pipe lengths by size and class is to be included on the drawings. Separate pipe schedules will be shown for County and private systems.
- s) Elliptical pipe structural designs are to conform to the ASTM Designation C507. A note on the drawing must specify this designation, the use of wire mesh reinforcement and sand bedding for the elliptical pipe is required.

**Table 4-6** depicts standard elliptical pipe sizes and the circular pipe size with the approximately same cross sectional area.

**Table 4-6 – Elliptical and Circular Pipe**

Elliptical Pipe		Circular Pipe		Elliptical Pipe		Circular Pipe	
Span x Rise	Area	Diameter	Area	Span x Rise	Area	Diameter	Area
<i>inches</i>	<i>sq. ft.</i>	<i>inches</i>	<i>sq. ft.</i>	<i>inches</i>	<i>sq. ft.</i>	<i>inches</i>	<i>sq. ft.</i>
-	-	15	1.23	83 x 53	24.8	66	23.76
23 x 14	1.8	18	1.77	91 x 58	29.5	72	28.27
-	-	21	2.41	98 x 63	34.6	78	33.18
30 x 19	4.1	24	3.14	106 x 68	40.1	84	38.48
34 x 22	5.1	27	3.98	113 x 72	46.1	90	44.18
38 x 24	6.3	30	4.91	121 x 77	52.4	96	50.27
42 x 27	7.4	33	5.94	128 x 82	59.2	102	56.75
45 x 29	8.8	36	7.07	136 x 87	66.4	108	63.62
53 x 34	10.2	42	9.62	143 x 92	74	114	70.88
60 x 38	12.9	48	12.57	151 x 97	82	120	78.54
68 x 43	16.6	54	15.9	166 x 106	99.2	132	95.03
76 x 48	20.5	60	19.63	180 x 116	118.6	144	113.1

\* American Concrete Pipe Association

## **4.4 Bridges and Culverts**

### **4.4.1 General Considerations**

In the past, culverts and other stream crossings were often sized strictly to convey the design discharge associated with the project. Little thought was given to the long term environmental impacts associated the construction of stream crossings. While the stream crossings function to convey the peak discharge, the stream crossings become barriers to aquatic habitat due to channel degradation or migration and impact wetlands or riparian habitats.

Montgomery County promotes use of environmentally sensitive stream crossings. Environmentally sensitive stream crossing promote the passage of aquatic habitat and minimize impact to wetlands and riparian buffers that surround streams; thereby, promoting environmental stability. Where existing aquatic blockages occur, the County encourages the retrofit or replacement of culverts to promote aquatic habitat. Due to economics, the County attempts to balance the environmental benefits with cost effectiveness for construction and future maintenance. County design considerations minimize

environmental impacts to aquatic passage, wetlands, and natural habitat of the stream valley, while adhering to prescribed hydraulic criteria.

While this chapter establishes a set of guidelines that facilitate environmentally sensitive design of bridges and culverts for stream crossings in Montgomery County, the guidelines are intended to provide the design engineer with criteria and information for selection of an appropriate location and a suitable structure, while maintaining the natural integrity of the stream valley. However, these criteria are not intended to supersede the regulatory authority of the various Federal, State, or local permitting agencies that must be coordinated with during design and approval of the project. All of the proper paths and requirements for submission of waterway and wetland construction permits will be followed.

The goal of these guidelines is to provide methods for the design and construction of roadway stream crossings which overcome issues experienced with past roadway construction design practices.

These goals are to:

- Eliminate the degradation of the stream habitat, aquatic life, and water quality;
- Recognize and avoid the creation of physical blockages and impediments to the passage of fish and other aquatic life;
- Minimize the burden of infrastructure construction and maintenance for County taxpayers; and
- Coordinate and unify the requirements and needs of the various regulatory agencies involved in the environmental review of roadway stream crossings.

These guidelines apply to all projects which cross or intend to cross streams with a perennial flow or streams with intermittent flow in defined channels identified by United States Geological Survey (USGS) maps, Maryland-National Capital Park and Planning Commission topographic maps, or the current Natural Resources Conservation Service (NRCS) soil survey maps.

#### **4.4.2 Classification and Review**

Any culvert with diameter over six feet is designated and reviewed as a bridge. Box culverts wider than six feet are designated as bridges. Multi-cell culverts are designated as bridges if the distance (gap) between the cells is "one half pipe diameter or less" and the total span (outside edge of cell to outside edge of cell) is more than six feet. If the gap between cells is more than one half pipe diameter, each cell is considered an individual culvert and the multi-cell culvert is not designated as a bridge.

For multi-cell culverts situated at an skew angle to the road (vs. the typical perpendicular orientation), the span is measured along the centerline of the road from outside edge of cell to outside edge of cell, and the same six-foot span threshold applies for designation as a bridge.

Any culvert designated as a bridge will require review by the MCDOT Bridge Review Section.

#### **4.4.3 Design Considerations**

Culverts shall be designed to convey flows generated by the fully developed, or as currently zoned, (whichever is denser) upstream drainage area based on the functional classification of the roadway (See Section 3.1). The method for hydrologic computations shall coincide with the methods outlined in Section 3 of this manual. Headwater calculation should be completed using HDS-5 methodology or similar culvert sizing format.

Tailwater for the culvert calculations shall use historical records or FEMA map water surface elevations where they are applicable. For culvert design storms other than what is available through historical records or FEMA mapping, the Manning's n-values for the tailwater reach shall be calibrated so that peak discharge water surface elevations match the known water surface elevations for the known/historical design storms. Using the calibrated Manning's n-values, the water surface elevation for the required design storm shall be calculated and used as the tailwater elevation.

For culverts not within a gauged or FEMA analyzed reach, open channel calculations should be used to



estimate the tailwater elevation by determining the water surface elevation for the peak discharge for the design storm. For open channel calculations, use the Manning's formula and Manning's n-values provided in Appendix B.

#### **4.4.3.1 2-Year Channel**

Channels with a base flow will typically be designed with a 2-year channel. The following information is provided for information only. Review and enforcement of criteria for 2-year channels within culverts will be at the discretion of other agencies such as the USACE or MDE during the Joint Permit Application Process.

Where practical, the proposed culvert will have, at a minimum, the same span as the existing channel. The portion of the culvert located within the channel must be designed to have the capacity to convey the 2-year runoff. There should be little to no increase in the water surface elevation for the portion of culvert located within the channel. The remainder of the culverts or structures may be placed either beside the culvert or in the floodplain. During transition grading between floodplain and culvert, grading of the 2-year channel is not allowed unless approved by Montgomery County (along with MDE and USACE if required). Transition grading of the floodplain to and from the culverts above the bank elevation of the 2-year channel is preferred.

Where open or closed bottom culvert spans are significantly larger than the 2-Year channel width, the culverts shall be designed to incorporate a sub-channel at the same dimensions and roughness of the existing conditions. Barrels of closed bottom culverts will be counter sunk to promote aquatic passage on culverts that require a Joint Permit Application.

#### **4.4.3.2 100-Year FEMA Floodplain and MCDPS Floodplain District**

Culverts for roadway embankments within the FEMA delineated floodplain will be designed so there is no increase in the 100-year water surface elevation for the proposed condition. When an increase in water surface elevation is unavoidable, the area affected by the increase in elevation will be contained within a floodplain easement.

MCDPS defines the Floodplain District in Chapter 19, Article III of Montgomery County Code as "any waterway with a drainage area of 30 acres or larger." Disturbance within an MCDPS defined Floodplain District, must be permitted by MCDPS. Floodplain District design criteria may be more stringent than design criteria within this manual.

#### **4.4.3.3 Material Selection**

Pipe culverts shall be constructed of Reinforced Concrete Pipe (RCP) unless otherwise approved by MCDOT Structures Division prior to design. Materials shall meet the material and cover requirements contained in the MSHA Drainage Manual and MSHA specifications.

The design and construction of bridges and culverts designated as bridges shall comply with AASHTO and MSHA Standard Specifications.

**4.4.3.4 Service Life**

The design service life for drainage facilities shall conform to the following criteria.

**Table 4-7 – Culvert Service Life**

<b>Service Life (Years)</b>	<b>Drainage Facility</b>
100-Year	Expressway or Principal Arterial
75-Year	Roadways greater than 27 feet wide and or greater than 10-feet cover
50-Year	All other pipes within right-of-way

*Note : Conforms to SHA Guidance*

**Table 4-8 – Material Rating For Service Life**

<b>Service Life (Years)</b>	<b>Drainage Facility</b>
100-Year	No pipe material meets the 100-year service life criteria. The designer shall consider environmental conditions and demonstrate adequacy of the material or what additional protection is required for the site.
75-Year	RCP -Class IV (Unless Chloride exceeds 500ppm; Sulfate (SO4) exceeds 150 PPM; pH less than 4.5), CPP, Corrugated Polyethylene, PPWP-Polyviinyl Chloride Profile Wall
50-Year	FCP - Non-Asbestos Fiber Cement

*Note : Conforms to SHA Guidance*

**4.4.3.5 Skewed Pipes**

Culverts shall be as close to perpendicular as possible to the proposed roadway alignment. This will reduce material costs, the amount of roadway impacted and the duration of traffic diversion during installation and eventual replacement. Where culvert skew is required due to the existing channel alignment, the culvert shall be skewed along the stream to the minimum extent practical for the proposed roadway alignment. Culvert skew angle shall not exceed 45 degrees. (See Figure 4-5)

**Figure 4-5 - Culvert Skew Length**

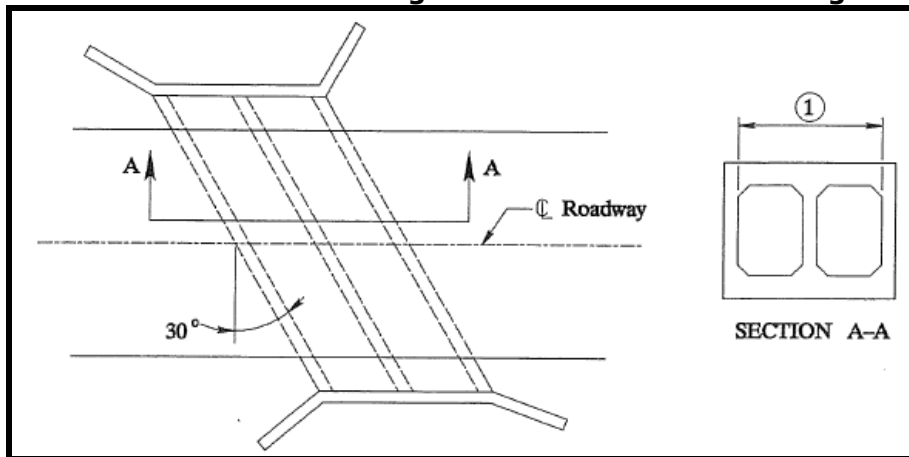

**Figure 4-6 - Culvert Skew Length**

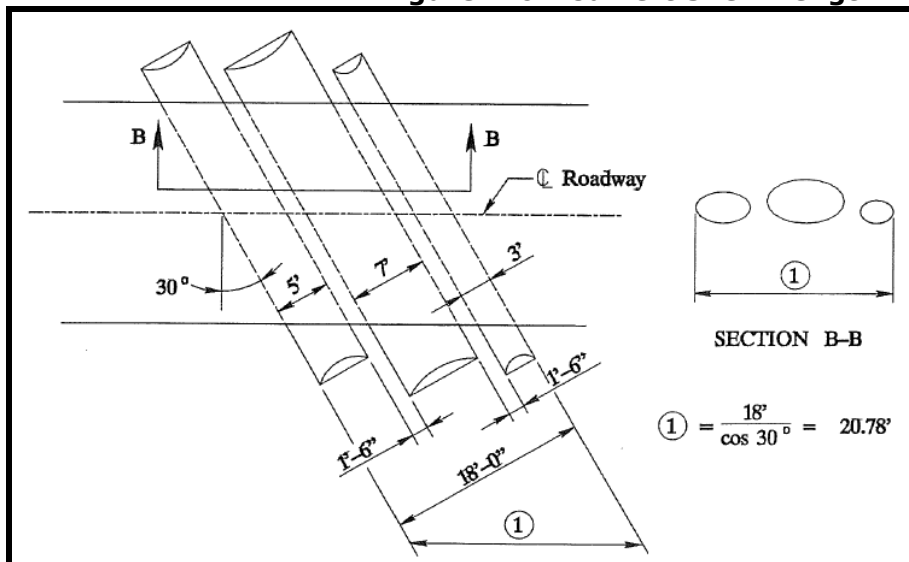

**4.4.3.6 Multiple Pipes**

Culvert spacing will be a minimum of one-half pipe diameter or 3 feet; whichever is less. Multiple pipes must have a single barrel sized adequately to convey the bankfull runoff and promote aquatic passage. The additional culverts shall be situated within the floodplain to facilitate conveyance of high flows; however, the additional culverts should not promote lateral movement of the 2-year runoff channel. This can be accomplished with inverts that are slightly higher than the invert for the barrel that conveys the 2-year runoff channel.

#### **4.4.3.7 Headwater (Allowable)**

The maximum allowable headwater must conform to several requirements to protect both County and private property surrounding the culvert entrance.

- The headwater to depth (HW/D) ratio should be 2.0 or less for the design storm event corresponding to the roadway classification outlined in Section 3 of this manual. However, where approved by MCDOT the HW/D ratio may increase for environmental or site constraints provided the roadway embankment is designed as an Earth Embankment per Maryland NRCS Pond Code 378.
- When the design storm is exceeded and roadway tops, no increase in water surface is allowed without purchase of a S.D. Easement or applicable FEMA revisions.
- Headwater shall be a minimum of one (1) foot below the shoulder for the design storm event.
- No encroachments to upstream property will be allowed for the design event.
- Coordination with MCDOT will occur where existing headwater conditions impact public or private property not associated with the project. Criteria for this condition will be set on a case-by-case basis.

#### **4.4.4 Site Inventory**

MCDOT recommends performing the site inventory at the same time the Natural Resources Inventory (NRI) is completed or as early in the design process as feasible. Because lot layout and project yield are contingent on the location of the streets, the inventory should be completed prior to submission of the Preliminary Plan Review. While stream crossings are often dictated by the geometric layout of the roadway, the storm drain designer should make efforts to find the best possible site for the stream crossing. Assessment and mapping of the following natural resources are necessary in order to assist in properly locating a crossing:

- Existing stream channel geometry (cross sectional and longitudinal)
- Width, depth, and velocity of normal flow (base flow).
- Width, depth, and velocity of the bankfull storm event.
- Locations of wetlands and wetland type (i.e., forested shrub/scrub, etc.)
- Location of steep slopes
- Location of high quality forest
- Floodplain characteristics (geometry, slope, soils, etc.)
- Stream bed and stream bank composition

A site visit is necessary to gather baseline information for these factors. At a minimum the stream walk will include conducting a photographic inventory, completing habitat and biological assessments, while confirming soils, wetlands, steep slopes, and other factors. See **Appendix D** for a sample field inventory form.

## ***4.5 Entrances and Exits in Storm Drain Systems***

The use of Federal Highway Administration publication HEC-22 Urban Drainage Design Manual is recommended as sources of information on the design of entrance structures.

### **4.5.1 Storm Drain System Entrances and Stabilization**

#### **4.5.1.1 General Considerations**

Entrances to storm drain systems can consist of headwall entrances to enclosed drainage systems or culvert entrances. Adequate field run or aerial topography is required to ensure that the storm drain system is aligned with the existing or proposed flow path. In addition, the limits of ponding shall be displayed on the construction plans and pipe profiles for the headwater associated with the design storm and 100-year storm events. The channel invert and tops of banks of the incoming drainage course(s) are to be shown on the plan and profile views.

Storm drain entrances are not to be located on developed lots except in extenuating circumstances, with special permission of MCDPS. Unless otherwise approved, the 100-year storm backwater elevation should be located outside of lots or be contained within a ponding easement to limit construction within the ponding area. An increase of one foot or greater in the 100 year headwater elevation off-site will require a 100-year flood plain easement.

An end section or headwall is to be used where the entrance is to be the terminus of the enclosed system. A cutoff wall may be used when future extension of the system is anticipated. The structure shall be located sufficiently beyond the proposed development so that re-grading will not be required on occupied lots of this development when the system is extended.

#### **4.5.1.2 End Treatments**

All culverts and pipes (entrance or exit) will be protected with end treatments.

- Headwalls
  - Use to anchor pipes to prevent uplift
  - Must be outside the clear zone (clear zone as defined by AASHTO)
  - Must be beveled based on standard details
  - Improved inlets shall only be used when approved by MCDOT
- Wingwalls
  - Use to contain roadway fill for culverts  $\geq$  4 foot rise
  - Use when channel side slope are unstable
  - Use when culvert is skewed to the normal channel flow
- End Sections
  - Use if no base flow is present
  - No backwater conditions are anticipated
  - Span is less than 36 inch, 30 inch within the clear zone

All end treatments shall be protected from traffic.

- Culverts/pipes less than 30 inches located within the clear zone shall use a safety slope end section or sloped headwall,
- Culverts/pipes greater than 30 inches may have various treatments as follows:
  - Extend pipe to have headwall outside clear zone

- If pipe extension is not possible, shield end treatment with traffic barrier

#### **4.5.1.3 Longitudinal Storm Drain with End Treatments**

For County storm drain systems (not cross culverts) where headwalls are used in lieu of inlets, headwater computations for design storm and 100 year storms shall be provided. The maximum relationship of the headwater depth to the pipe diameter (HW/D) shall be in accordance with section 4.4.3.2 for the design storm; however, the limits of ponding for the 100-year storm shall be contained in an easement. This condition allows the 100-year storm to top the roadway and flow in the gutter.

#### **4.5.1.4 Channel Transitions**

During design of storm drain systems, sump conditions are occasionally utilized to enclose the headwater in a smaller footprint. Sump conditions are created when the entrance invert is placed below the grade of an existing channel. When this occurs in a ditch without an ordinary high water mark, a gabion or concrete channel shall be used as erosion protection of the depression as well as a portion of the existing channel immediately before the depression. Where an ordinary high water mark is present, the designer shall refer to the aquatic passage section of this report. Where the channel invert is at a gradual slope, other erosion protection may be used with MCDPS' approval. Protection is to be provided, as necessary, to prevent erosion. Transition of the natural section to the protection section is to be shown on the plan and profile views along with typical sections.

### **4.5.2 Outlet Structures**

#### **4.5.2.1 General Considerations**

Outfalls reconnect enclosed storm drain systems to an existing, established, drainage course or stormwater management facilities. Adequate field run or aerial topography is required to ensure that the storm drain system is aligned with the existing or proposed flow path.

Outlets are not to be located on developed lots except in extenuating circumstances, with special permission of MCDPS.

#### **4.5.2.2 Storm Drain Systems**

- 1) Field run topographic information is to be shown on the plan and profile views to show the drainage path from the structure to an existing, established, drainage course.
- 2) The channel invert and tops of banks of the receiving drainage course are to be shown on the plan and profile views.
- 3) Protection is to be provided to prevent erosion. Transition of the protection section to the natural section is to be shown on the plan and profile views along with typical sections.
- 4) An end section or endwall is to be used where the outlet is the terminus of the enclosed system. A cutoff wall may be used when future extension of the system is anticipated.
- 5) The structure shall be located sufficiently beyond the proposed development so that re-grading will not be required on occupied lots of this development when the system is extended.
- 6) Where the vertical height at the inlet/outlet of a storm drain system exceeds 4 feet, a 48 inch minimum height chain link fence will be required for safety purposes.
- 7) Standard MC-521.01 shall be used at all temporary outfalls and end walls at all permanent outfalls.
- 8) Riprap channel protection should consist of plunge pools or riprap aprons as outlined in the MDE Erosion and Sediment Control Manual to provide adequate outlet protection.

### **4.5.3 Outlet Velocity**

#### **4.5.3.1 Storm Drains**

The partial flow velocity based on the actual slope of the outlet pipe is to be computed. Computations must be provided to substantiate that the partial flow velocity is less than 10 fps for the 10 year storm unless a suitable energy dissipater is placed at the outlet.

Computations must also be provided to substantiate that the velocity, from the dissipater, concrete, gabion or riprap channel, etc., to the existing channel is reduced to 5 fps (or less). Outlets that outfall into storm water management facility shall be subject to the approval of the Montgomery County Department of Environmental Protection (MCDEP) and MCDPS.

#### **4.5.3.2 Culverts**

When the grade immediately beyond the outlet protection is sufficiently steep for the flow velocity to increase beyond 5 fps, gabion or riprap protection is to be provided unless documentation is provided showing the vegetation and soil is erosion resistant.

### **4.5.4 Types of Inlet and Outlet Stabilization for All Structures**

#### **4.5.4.1 Location**

Where possible, the crossing location should minimize the need to use rip-rap in the stream channel.

- 1) At **Single Cell Culvert (*inlet*)**: rip-rap within the stream channel should only be used when necessary, and then only immediately adjacent to the headwall. Riprap upstream of culvert should be used for grade control only when located within the channel. Other areas disturbed upstream of the inlet should be stabilized with soil erosion control fabrics and/or with native stream bed materials. Side slopes should be sodded or otherwise protected with vegetation. A concrete headwall with a footing of appropriate depth will be constructed to protect the roadway embankment from erosion due to scour.
  - a) At **Single Cell Culvert (*Outlet*)**: rip-rap shall be used only when other methods employed to prevent scour of the stream channel are not practical. The size of rip-rap and length of rip-rapped channel or apron are dependent on the flow velocity of the 10-year storm. Side slopes of the stream channel should be rip-rapped to the top of the pipe(s). The slope of the rip-rapped -channel should be as close to the natural stream channel as possible. The anticipated scour depth will be computed for the entire culvert as necessary. A concrete endwall with a footing of appropriate depth shall be constructed to protect the roadway embankment. The depth of anticipated scour will be calculated in accordance with the most current version of HEC-18, or other acceptable method approved by MCDOT and MCDPS.
  - b) For **multi-cell** installations, stabilization of the inlet and outlet ends of the low flow cell shall be accomplished in the manner outlined above for the single cell culvert. The inlet and outlet ends of the flood cell pipes shall be stabilized for the 10-year storm. This stabilization should be placed so that it does not extend into the stream channel.

#### **4.5.4.2 Order of Preferred In-stream Stabilization Techniques**

Design and analysis of stabilization techniques occurs where concentrated flow is encountered within the limits of the project site. Concentrated flow points consist of swales, ditches, and channels that are either temporary or permanent. Swales and ditches where vegetative stabilization can occur should be lined on the sides and bottom. Multiple stabilization techniques may be required for ditches or streams where existing channels do not support vegetation. Riprap may be used to stabilize the channel bottom where geo-textile or vegetation may be used on side slopes or within the limits of the floodplain.

While ultimate approval of stream work is the jurisdiction of MDE and the USACE, stream design submissions should be reviewed and approved by MCDEP prior to submission to the State and Federal agencies.

- 1) **No Additional Stabilization:** Quantity of flow and velocity are proven to be non-erosive for a specific flow path.
- 2) **Vegetative/Biological Stabilization:** Velocity reduction and/or erosion control by the use of naturally occurring surface treatments only (i.e., grass, sod, and tree spikes). Vegetative/biological stabilization may be supplemented with stream restoration where the banks of an existing stream channel is to be returned to a more natural series of riffles, runs, and meanders, thereby decreasing the flow velocity.
  - a) **Geotextile Stabilization:** Use to minimize erosion where vegetation can be planted and expected to grow through the material. The choice of a geotextile for application must be consistent with its documented performance.
  - b) **Rip-rap with low flow (pilot) channel:** Use when design flow exceeds erosive velocity and stream channel degradation cannot be reduced by other methods.
  - c) The use of entrance rip-rap should be minimized or limited to only situations where substantial fill or cut must occur for the correct or necessary culvert alignment and to prevent head cutting.
  - d) The use of rip-rap at the outlet of a culvert should be limited. The length should be not more than what is necessary to attain a velocity below 5 fps for the 10 year storm event. Once this velocity is obtained the use of "natural" methods of preventing erosion and scour must be examined.
  - e) Whenever possible the pilot channel bottom should be on natural substrate. If necessary, a well anchored and appropriate geo-textile may be employed on the bottom of the low flow channel of an intermittent stream, where the natural substrate cannot withstand the designed velocity.
  - f) **Rip-rap:** The use of rip rap in the stream bed will be limited to those situations where the erosive velocity in the low flow channel cannot be reduced or compensated for by other means. In all cases when rip-rap is employed, the material used should be protected from increasing water temperature through solar heating by providing a means of shading or otherwise protecting it from direct sun exposure. All void spaces should be filled with soil excavated from the stream bed or material of similar size. The intent of this practice is to maintain the normal stream flow depth and velocity.
  - g) **Step-Pools and In-Channel Berms:** Step-pool channels and In-channel berms may be utilized to protect channel banks from scour. Details for step pools may be obtained from MDE's Guidelines for Waterway Construction. Rock for these features shall be designed in accordance with stable channel design practices outlined in HEC-22 or as defined by other stream acceptable stream restoration practices.



## **4.6 Open Channels**

### **4.6.1 Design Requirements**

Computations shall be provided for all channels, accompanied by a typical section of each reach, and a plan view with typical section locations clearly marked. In the case of existing streams or swales which are to remain in a natural condition, field run survey data is necessary to prove the streams will remain in a stable condition.

- Field run survey is necessary for a maximum length of 200 linear feet to prove the channel is and will remain in stable condition.
- The channel invert and tops of banks are to be shown in plan and profile views.
- For designed channels, a cross sectional view of each configuration shall be shown.
- For designed channels, limits of grading shall be shown.
- The limits of a recorded 100 year flood plain easement or surface drainage easement sufficient to convey the 100 year flow shall be shown. A standard storm drain easement for improved systems is not to be obtained for natural channels.
- For designed channels, transitions at the entrance and outlet are to be clearly shown on the plan and profile views.
- Limits and types of bank protection are to be shown on the plan and profile views.

### **4.6.2 Design Channels**

Open channels will be designed for the appropriate design storm. Any open channel within a floodplain district must be permitted through MCDPS. MCDPS defines a floodplain district as an area having a drainage area of 30 acres or more. When used, they must be designed for the appropriate design storm with a minimum freeboard of 0.5 feet to the top of the channel. Velocities in the channel and banks must be such that erosion will not occur or appropriate stabilization must be applied. Refer to the permissible velocities in Table 4-11.

Computations shall include slope, cross section, roughness coefficient, velocity and quantity of discharge for each section or reach of channel, unless otherwise directed by MCDOT the Manning's Equation will be used for channel design. Where perennial or intermittent streams are encountered or a base flow is present for extended periods, the designer should consider implementing a sub-channel that displays characteristics of natural channels. These channels may require a Joint Permit to be submitted with the USACE and MDE. Open channels (such as Bio-swales) may also be used to satisfy Environmental Site Design (Road Code) requirements in addition to large discharge conditions that require open channels

Each open, designed channel must have the following shown on a cross section within the submitted plan set:

- Channel Dimensions
- Channel Side Slopes
- Design storm water surface elevation
- Bankfull and Base flood elevation (if required for Joint Permit Application)
- Riprap classification
- Riprap blanket thickness

### **4.6.3 Natural Channels**

Natural channels are alluvial channels formed through long term geomorphic activity including erosion and sedimentation. The channels generally have irregular cross sections and display a meandering plan form.

Where possible, natural channels should be avoided or spanned to minimize environmental impacts at a site. Where avoidance is not possible or economically feasible, channel realignment or stream restoration may be required. Since natural channels are often the jurisdiction of the United State Army Corps of Engineer (USACE) or Maryland Department of Environment (MDE), the appropriate permits must be obtained to realign or restore natural channels. These State and Federal Permits are associated with the Clean Water Act (CWA) and consist of the 401 and 404 water quality permits. In the State of Maryland, the 401 (State) and 404 (Federal) permits are applied for using a Joint Permit Application (JPA) that both agencies review and approve. When natural channels are impacted by County storm drain systems or bridges, a pre-permit meeting must be held and include the appropriate County representatives from MCDOT and MCDEP.

#### **4.6.3.1 Classification of Natural Channels**

Classification of natural channels is a function of the form (morphology) and process (mechanics) associated with the geomorphic characteristics of the channel. Channel classification is a key aspect for re-alignment or restoration of a stream. Since there are several channel classification systems that exist, the method of classification should be presented to the permitting agencies at the pre-permit meeting to ensure that the method utilized is appropriate to the site. Some of the more well-known classification systems include Brice and Blodgett (1978), Schumm (1981), Mollard and Janes (1984), and Rosgen (1994).

#### **4.6.3.2 Design of Natural Channels**

Since there are many different aspects to natural channel design, the goal of natural channel design for Montgomery County shall be to provide a stable natural channel that promotes aquatic passage within the watershed. Naturally stable channels are able to move water and sediment from the watershed and maintain a stable dimension, pattern, and profile.

Numerous State or Federal agencies provide resources to promote design of stable natural channels and aquatic passage. The “Maryland Guidelines for Waterway Construction” established by MDE should be utilized where possible to aid in the review and approval of permits.

Other Channel (Stream) Restoration References include:

**National Engineering Handbook (Part 654) Stream Restoration Design;** United States Department of Agriculture/Natural Resource Conservation Service

#### **4.6.3.3 Temporary Impacts to Natural Channel**

Temporary impacts to natural channels are often unavoidable for construction of bridges, piers, culverts, and other project related items. Temporary impacts to natural channels must be permitted and approved by the appropriate agencies. In order to aid in construction, the “Maryland Guidelines for Waterway Construction” includes details to facilitate construction and permit approval.

#### **4.6.3.4 Permitting Aids**

##### Maryland Nontidal Wetlands and Waterway permitting

Within Montgomery County, numerous streams and tributaries are considered Federal or State Waterways. The designer must be cognizant of the whether the proposed storm drains will impact any Federal or State waterways. A joint permit application must be submitted for any project that impacts the following:

- Wetlands
- Waterways
- 100-year floodplain

Joint permit applications are required to comply with the clean water act. Due to revisions every few years, the designer shall obtain the most current copy of the permit from the Maryland Department of the Environment website or other official resource.

##### Maryland Waterway Construction Guidelines

The Maryland Waterway Construction Guidelines manual provides a set of recommended details for approaches frequently encountered during construction in a waterway. These measures and techniques are provided as a basis of design when construction occurs within or adjacent to a waterway.

- Temporary In-stream Construction Measures
- Slope Protection & Stabilization Techniques
- Channel Stabilization & Rehabilitation Techniques
- Stream Crossings

The designer should be familiar with the techniques included within this manual for the design of storm drain systems. The guidelines are available on-line from MDE at the following website.

<http://www.mde.maryland.gov>

#### **4.6.4 Roadside Ditches**

Generally, the use of these criteria for roadside ditches shall be used in connection with the design and construction of new rural roadways. However, the criteria may be applied in other cases, e.g., to existing roads without curb and gutter, median ditches, and Environmental Site Design (ESD).

Ditches are considered integral components of the County drainage system. Generally, roadway ditches shall be a trapezoidal shape in accordance with MCDPS standard details MC-2001.01 through MC-2008.12. Trapezoidal ditches are preferred when used for storm water quality management measures such as grassed or bioretention swales. Other channel cross sections will be considered for approval under certain conditions. They shall be designed to provide sufficient hydraulic capacity to convey the estimated runoff from a 10-year frequency storm at a non-erosive velocity. The estimated runoff shall be calculated using the methods described in the Section 3 of this manual.

Ditch capacity shall be calculated using Manning's formula. The appropriate roughness coefficient for the ditch lining under consideration shall be selected from Table 4-9 below. The maximum average velocity shall not exceed the following:

**Table 4-9 – Ditch Lining & Velocity**

<b>Channel Lining</b>	<b>Permissible Velocities (fps)</b>
Earth, no vegetation	1.0 to 3.0
Seed and Mulch	0.0 to 2.5
Grains, Stiff Stemmed grasses	2.0 to 3.0
Bunch Grass	2.0 to 4.0
Solid Sodding	0.0 to 4.0
Stiff Clay or Clay & Gravel	3.0 to 5.0
Fine Gravel	0.0 to 5.0
Well Established Grasses, short pliant blades	0.0 to 5.0
Soil Stabilization Matting, over seed & Mulch	0.0 to 5.0
Shale and Rock	0.0 to 5.6
Course Gravel	0.0 to 6.0
Riprap (Varies)	Varies ( <i>Refer to SHA 61.1 - 405.1</i> )
Concrete Channel	0.0 to 20.0

The minimum acceptable grass v-ditch gradient is 2.0 percent. The minimum acceptable grass flat bottom ditch gradient is 2.5 percent. Concrete lining shall only be used when velocity exceeds the maximum allowable for grass ditches or when the ditch gradient is less than 2.0 percent. The minimum acceptable concrete ditch gradient shall be 1.0 percent. In certain instances when grass or concrete lining is not deemed appropriate by the designer, other materials may be considered and approved by MCDPS. A waiver request may be submitted to MCDPS for ditches that cannot meet the minimum required grades due to the roadway longitudinal grade or if the ditch is to be used as a required storm water management practice. A waiver for ditch slopes unable to meet designated slope is not considered to be a “road code waiver”.

The maximum permitted depth of flow for any side ditch shall be one foot. When this depth is exceeded, the runoff must be intercepted by an appropriate storm drainage inlet and conveyed in a pipe from that point to an acceptable outfall. In those situations where introducing an enclosed drainage system is not feasible, with prior approval of MCDPS, a change in the ditch section characteristics may be permitted. Except at driveway crossings and street crossings where the outlet conditions allow for ditch flow (i.e., depth exceeds one foot) enclosed pipe systems must be used in lieu of culverts.

The design plans for any roadway having a roadside ditch shall show for the ten year design storm the estimated velocity (V) in fps, depth of flow (D) in ft., and quantity of flow (Q) in cfs for the following:

- Ditches at intersections
  - Where ditches terminate at intersection
  - Where ditch flows from side roads to mainline around fillet
  - Where ditch flows to mainline from side road
- 500-foot intervals of road centerline length
- Uphill side of all inlets
- Both flow directions of the ditch leading into a sump
- Locations where ditch flow, depth, or velocity is significantly affected by
  - Offsite ditches or pipes connecting to ditch
  - Increase in drainage area

- Change in ditch gradient or roughness

Ditch invert elevations shall be shown on the design plans at the following locations:

- Around intersection fillets
- 50-foot intervals through crest and sag vertical curves
- around the bulb of cul-de-sacs
- through transitions from swale sections to full ditch sections
- and at other critical, points
  - temporary turnarounds
  - low points
  - high points

## **4.7 Riprap**

### **4.7.1 Riprap Outfall Protection**

#### **4.7.1.1 Riprap Apron**

Riprap channels placed at storm drain outlets as energy dissipaters will be designed to reduce the 10-year design storm velocity at the downhill end of the channel to 5 fps or less and shall be placed on a slope range of 0.1 thru 0.5 percent.

A typical section and plan view of the riprap channel will be provided. Additionally, it will be shown graphically on the storm drain plan and profile. The information required to be shown on the plans, shall include  $d_{50}$  stone size, class, side slopes, depth, length, width and thickness of blanket. In all cases where riprap is used at inlets or outfall, a toe (cutoff) wall shall be provided to prevent scour. Toe wall shall extend the entire width of riprap and shall have dimensions with width and depth equal to the depth required for the riprap class being utilized at the inlet or outfall.

Using the method in the U.S. Army Engineer Waterways Experiment Station's, "Practical Guidance for Design of Lined Channel Expansions at Culvert Outlets: Hydraulic Model Investigation" Technical Report H-74-9, page A12, computations will be as follows:

- 1) Determine tailwater, either within the receiving stream or normal depth within the design riprap channel, whichever is greater.
- 2) Determine the required  $d_{50}$  size of the stone:
  - a) Circular and Square outlets:

$$\frac{d_{50}}{D} = 0.020 \frac{D}{TW} \left( \frac{Q}{D^{5/2}} \right)^{(4/3)} \quad 4-9$$

- b) Rectangular and other shaped outlets:

$$\frac{d}{D} = 0.020 \left( \frac{D}{TW} \right) \left( \frac{q}{D^{3/2}} \right)^{(4/3)} \quad 4-10$$

Where:

- $d_{50}$  = Diameter of Average Size Stone (ft)
- D = Diameter of outlet for circular, Height for all other shapes (ft)
- TW = Tailwater Depth above invert of storm drain outlet (ft)
- Q = Discharge (cfs)
- q = Unit Discharge per foot of width for rectangular and other shaped outlets (cfs/ft)

3) Determine the required length of the blanket:

a) Circular and Square outlets:

- TW < 0.5D

$$\frac{L}{D} = 1.8 \left( \frac{Q}{D^{5/2}} \right) + 7 \quad 4-11$$

- TW  $\geq$  0.5D

$$\frac{L}{D} = 3 \left( \frac{Q}{D^{5/2}} \right) \quad 4-12$$

b) Rectangular and other outlets:

- TW < 0.5D

$$\frac{L}{D} = 1.8 \left( \frac{q}{D^{3/2}} \right) + 7 \quad 4-13$$

- TW  $\geq$  0.5D

$$\frac{L}{D} = 3 \left( \frac{q}{D^{3/2}} \right) \quad 4-14$$

Where:

- $d_{50}$  = Diameter of Average Size Stone (ft)
- D = Diameter of outlet for circular, Height for all other shapes (ft)
- TW = Tailwater Depth above invert of storm drain outlet (ft)
- Q = Discharge (cfs)
- q = Discharge per foot of width for rectangular and other shaped outlets (cfs/ft)
- L = Length of the Stone Protection (ft)

The riprap channel bottom width will be equal to the width of the flared end section, when used, or 1.75 times the inside diameter of the outlet pipe or width of the outlet. The riprap channel side slopes shall be a maximum of 3:1. Where riprap channels are located at culvert or storm drain outfalls, the riprap channel should extend up the bank to at least the height of the pipe/culvert.

The blanket thickness shall be 2.0 times the  $d_{50}$  stone size or the theoretical spherical diameter of the maximum weight stone within the class of riprap required, whichever is greater.

### 4.7.1.2 Preformed Scour Pool

A pre-formed scour pool is an excavated hole or depression that is lined with riprap of a stable size to prevent scour. Since the depression dissipates excessive energy in turbulence by allowing both vertical and horizontal expansion downstream of the culvert, a significant reduction in stone size is achieved by the excavation. The two types of preformed scour holes are as follows:

Type I – The depression is equal to one-half of the culvert rise

$$D_{50} = 0.0125 \left( \frac{d^2}{TW} \right) \left( \frac{Q}{d^{2.5}} \right)^{1.333} \quad 4-15$$

Type II – The depression is equal to the full culvert rise

$$D_{50} = 0.0082 \left( \frac{d^2}{TW} \right) \left( \frac{Q}{d^{2.5}} \right)^{1.333} \quad 4-16$$

Where:

- $D_{50}$  = Diameter of Average Size Stone (ft)
- $d$  = Diameter of outlet for circular, Height for all other shapes (ft)
- TW = Tailwater Depth above invert of storm drain outlet (ft)
- Q = Discharge (cfs)

For full design approach see Report Number FHWA-RD-75-508 “Culvert Outlet Protection Design: Computer Program Documentation” or FAA AC 150/5320-5C “Surface Drainage Design”.

### 4.7.2 Riprap Classification

Projects with storm water management must coordinate the riprap sizing and class type for storm water design with drainage design in order to avoid confusion in material selection.

**Table 4-10 – Riprap Classification**

Class	Gradation by Minimum (Maximum) Weight (lbs)			$D_{50}$ (in)	$D_{100}$ (in)	Minimum Thickness (in)
	0%	50%	10% (max)			
0	33	10	(1)	5.5	7	11
I	150	40	(2)	9.5	15	19
II	700	200	(20)	16	24	32
III	2000	600	(40)	23	34	46

**NOTE:** Table corresponds to MSHA and MDE Riprap Classifications

A filter will be placed between the riprap blanket and the underlying soil surface. The filter can be of two general forms: a gravel layer or geotextile. A gravel filter, when used, shall be designed by comparing particle sizes of the overlaying material and the underlying soil surface. The geotextile shall be as approved by MCDOT or MCDPS.

### 4.7.3 Riprap Bank Protection

Design of riprap bank protection should be designed based on either the Ishbash Equation per Section 2.1 of the Maryland Guidelines for Waterway Construction (MGWC) or Stable Channel Design using the

tractive force methods; whichever is greater. Stable channel design should utilize the methods outlined in the HEC-22 Urban Drainage Design Manual.

## ***4.8 Residential Lot Drainage Requirements***

The practices in this section are highly recommended; however, are not subject to review and approval by MCDPS.

### **4.8.1 Drainage Swales and Surface Drainage Easements**

A detailed study of the over-lot drainage patterns shall be required at the Preliminary Plan submittal to MCDPS. This study does not have to encompass the entire subdivision, only perceived trouble spots. Inlet locations shall be shown on the Final Road Construction Plans, as appropriate. Any required adjustments to the grades of the pipes and inlets may be made through the Red-line Revision process if the site development plan grades require different elevations than those on the approved Final Road Construction Plans. A flat grate type yard inlet shall be used and a safe overflow path shall be provided to the next downstream structure or conveyance system. Maximum 10-year ponding prior to overflow shall not exceed six (6) inches in case of blockage.

Swales shall be designed to convey runoff from the 10-year frequency storm event with a 0.5-ft freeboard. Yard inlets and culverts within residential yard swales must also be designed to maintain the 0.5-ft freeboard within the swale. At no point shall ponding of water occur within the Building Restriction Line (BRL). All ponding for the 10-yr storm shall be contained within a surface drainage easement. See Section 4.2 for inlet sizing criteria. This criteria applies primarily to surface drainage that is conveyed to County easements and the flow path to get the runoff to or from the County right-of-way or easement.

The centerline of a drainage swale or storm drain shall be 15 feet minimum to a residential structure. Swales or storm drains should be placed at the rear of the property beyond the Building Restriction Line (BRL) or in open space to maximize the use of the lot. When swales or storm drain pipes pass between residential units, the swale or pipe shall be centered between the units unless otherwise approved.

The maximum drainage area feeding any swale located in backyards and front yards shall be 2.5 acres. All flow shall be captured by a closed conduit system when the drainage area exceeds 2.5 acres.

The maximum drainage area to any swale between two (2) houses shall be 1.0 acre. If the distance between the two (2) houses is much greater than the typical 15 feet, a greater drainage area may be allowed to discharge to the swale. A designed swale shall be shown on the plans with the typical section and hydraulic data.

Required private surface drainage easements shall be used and granted to a Home Owners Association where applicable. The easement shall start at the next downstream property line after the swale accumulates 1.0 acre of drainage area. All easements shall be identified on the Site Development Plan (SDP) once final drainage paths are established and shall be recorded on a Final Plat. All easements shall be shown on the site development plan to provide notice to the homebuyers of their existence.



## 5 MISCELLANEOUS DRAINAGE

### 5.1 Sump Pump Discharges

Montgomery County regulates sump pump discharges to protect public safety and to prevent the creation of public nuisances. Property owners with sump pump drainage pipes located within County Right of Way must execute a "Declaration of Covenants" for maintenance of the system and indemnification of the County.

#### 5.1.1 Types of sump pump discharges allowed:

- 1) Discharge to an existing County facility
  - Existing facility can be an underground storm drain pipe, inlet, or manhole
  - Requires use of a backflow prevention valve
- a) Discharge to a roadside swale without curb
  - Discharge may not erode the swale
  - Erosion that occurs must be repaired by the homeowner
  - Erosion prevention may require a paved flume or specialty erosion control matting
- b) Discharge to a curb outlet or alternative discharge into right of way
  - Only allowed as a "Last Resort"
  - Requires discharge pipe through the curb
  - Approved on a case by case basis due to the potential of icy road conditions in the winter.

#### 5.1.2 Alternative Discharges of sump pumps

No approval required if alternative devices are located within private property.

- Dry Wells or Rain Barrels
- Rain Gardens
- Fee-in-lieu (contractor and/or developer pay for future County improvements to capture and convey sump pump discharge within the County right of way)

### 5.2 Driveway Culverts

Driveway pipes are to be utilized to provide conveyance of flow past driveways. While the maximum permitted depth of flow for any roadside ditch shall be one foot, a headwater of six inches above the crown is permitted for driveway culverts. Driveway culverts shall be designed to operate at the velocity of the incoming ditch, neglecting both entrance losses to the culvert and the pressure flow due to headwater. Ditch flow depths to driveway culverts may not exceed 1-foot. Drainage areas to driveway culverts may not exceed 2.5 acres. If 1-foot ditch flow depths are not attainable or the drainage area is greater than 2.5 acres, the flow must be conveyed through a closed (underground) pipe system.

The maximum drainage area allowed to cross a driveway on a pipe stem lot without a culvert shall be 1.0 acre. For driveways on pipe stem (Flag) lots with drainage areas exceeding 1.0 acre, a driveway culvert will be required to safely convey the flow.

Driveway entrances at high points along the roadway profile may qualify to have the driveway culvert waived provided that the grades on either side drain away from the driveway entrance.

All driveway culverts shall have a minimum cover of 1 foot. Pipe end section or end walls shall be installed on all driveway pipes; however, end walls shall only be placed when outside the clear zone for the proposed roadway in accordance with Standard MC-500.01. Safety slope end sections may be considered where end sections lie within the clear zone or as deemed prudent by the designer.

The driveway and driveway apron are to be maintained by the property owner. As an integral part of the driveway, the culvert, the end treatments for the culvert, and/or trench drains, if any, shall also be maintained by the property owner.

Driveway swales shall not be considered an adequate alternative to a driveway culvert and are not permitted. Trench drains may be considered in lieu of a culvert; however, the design must meet HS-20 loading requirements.

## **6 COMPUTER SOFTWARE**

### ***6.1 Federal and State Approved Software***

In order to ensure proper design of projects, Montgomery County supports the use of software developed and supplied by various Federal agencies and the Maryland State Highway Administration. While Montgomery County supports the use of software, it is the role of the Designer to utilize software correctly for the design conditions at the site. When completing a “Storm Drain” or “Hydrologic and Hydraulic Report”, it is the responsibility of the designer to provide a list of Federal and State software used for the project when it varies from the list below.

#### **6.1.1 Hydrologic Software:**

- TR-55 & Win TR-55
- TR-20 & Win TR-20
- HEC-1 (only when approved for a specific project)
- HEC-HMS
- GIS Hydro

#### **6.1.2 Storm Drain Software:**

- MPADD (Scupper Layout) MSHA
- BCAP (Broken Back Pipe Design)

#### **6.1.3 Bridge and Culvert Software:**

- 1) Culvert Analysis
  - HDS-5 Calculator (Estimation only not for final design)
  - HY-8
  - HEC-RAS
- 2) Bridge Analysis
  - HEC-RAS
  - WSPRO
  - TideRout2
  - HEC-1 (only when approved for a specific project)
- 3) Scour Analysis
  - HEC-RAS
  - HEC-1 (only when approved for a specific project)
  - Scour 8

## ***6.2 Third Party Software***

With numerous hydrologic and hydraulic software packages available from private vendors. Any software must be approved for use on the project. The County will evaluate need of the software for the project and provide approval on an as-needed basis.

Unless the County has a license and utilizes the software, the software will be rejected as the County will not be able to review data. When completing a “Storm Drain” or “Hydrologic and Hydraulic Report”, it is the responsibility of the designer to provide a list of third party software for the project.