

RAM XD™

8296 Portable Monitor Operating & Maintenance Instructions



TABLE OF CONTENTS

PRODUCT SAFETY INFORMATION.....	3
MONITOR CALLOUT DRAWING.....	4
SYSTEM COMPONENTS.....	5
OPERATING INSTRUCTIONS.....	7
MAINTENANCE INSTRUCTIONS.....	9
SYSTEM SPECIFICATIONS.....	10
MONITOR AND NOZZLE HYDRAULIC DATA.....	11
MOUNTING TEMPLATE.....	13

To view the most current parts list or drawings please visit www.elkhartbrass.com

PRODUCT SAFETY INFORMATION

- All personnel who may be expected to use this equipment must be thoroughly trained in its safe and proper use.
- Before flowing water from this device, check that all personnel (fire service and civilian) are out of the stream path. Also, check to make sure stream direction will not cause avoidable property damage.
- Become thoroughly familiar with the hydraulic characteristics of this equipment, and the pumping system used to supply it. To produce effective fire streams, operating personnel must be properly trained.
- Whenever possible, this equipment should be operated from a remote location. Do not needlessly expose personnel to dangerous fire conditions.
- Open water valves supplying this equipment slowly so that piping fills slowly, thus preventing possible water hammer occurrence.
- After each use, and on a scheduled basis, inspect equipment per instructions in the Maintenance section.
- Any modifications to the electrical enclosures will destroy the NEMA 4 rating and void warranty coverage of the enclosure and all components within.



Important: Before installing and operating provided equipment, read this manual thoroughly. Proper installation is essential to safe operation.

SYSTEM INFORMATION:

MONITOR SERIAL NUMBER: _____

MONITOR ACCESSORIES (NOZZLE GALLONAGE AND TYPE, TYPES OF TRANSMITTERS, WATER VALVE, ETC.):

MONITOR CALLOUT DRAWING

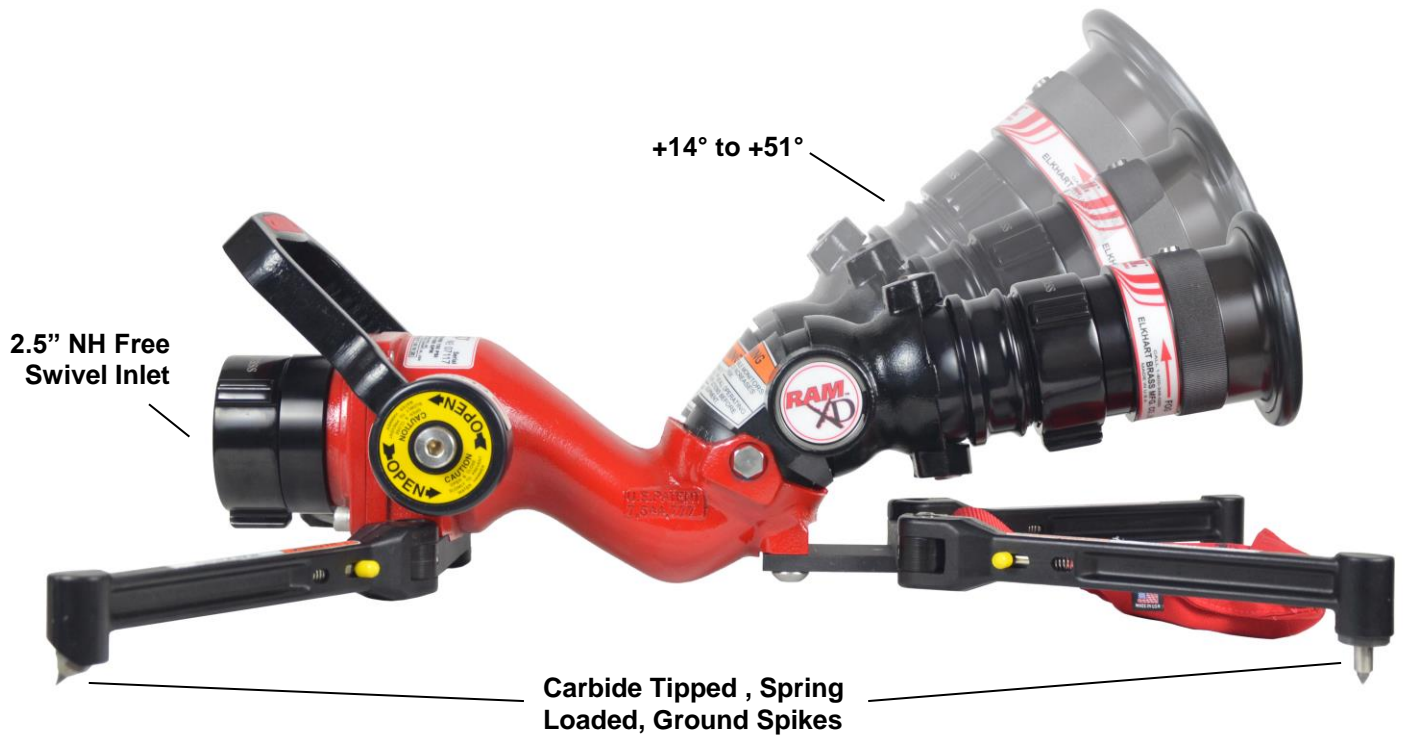

8296 **RAM XD** Monitor

SYSTEM COMPONENTS

MONITOR

RAM XD™ Monitor – 8296

The RAM XD (Rapid Attack Monitor) is designed to provide the fire-fighter / rescue personnel an efficient and distinct advantage in the application of water or foam at an incident site. This product is a lightweight aluminum device designed to a single operator the ability to deliver 500GPM of water as necessary. The monitor is self-contained and can be mounted in a pre-connect condition utilizing the truck mounting bracket such that quick deployment can be achieved for effective initial attack



RAM XD Monitor (8296)

Leg Pivot and Lock Pin

The forged aluminum legs have integral lock pins that are spring loaded for proper engagement when the legs are fully deployed. This provides a stable / reliable base for the monitor in use.

Forged Aluminum Legs

Forged aluminum legs provide superior strength over cast leg configurations.

Carbide Tipped Ground Spikes

The carbide tipped ground spikes provide secure engagement of the legs across a wide variety of soft and hard surfaces. The front spikes are spring loaded to assist engagement on uneven surfaces. Severe uneven surfaces where contact of all four legs cannot be achieved simultaneously should be avoided. The rear spikes are angled to provide greater contact in the direction opposing the reaction forces generated by the water flow.

Safety Strap

The monitor is supplied with a length adjustable braided nylon safety strap for use in securing the device to a fixed stable base prior to any use. The metal clip at the end of the safety strap makes attachment of the strap to a pole, tree, guard rail or other such fixture quick and easy. A pouch is provided to keep the strap organized during transport of the monitor.

Carry / Valve Control Handle

The large comfortable handle acts both as a carry handle in the fully closed and locked position and as a valve control handle to open / close the waterway.

Handle Lock Pin

A spring loaded lock pin with a large pull knob is provided to insure the carry / valve control handle remains in the closed position during any time water flow is not desired.

Counter Balance Mechanism

The counter balance mechanism keeps the nozzle position from drifting downward due to the weight of the nozzle / outlet devices. This mechanism must not be altered in any way and repair should only be conducted by Elkhart Brass personnel.

Safety System

The unique flow path generated by the lower and upper waterway pivot points provides two specific advantages. (1) The two pivot points provide a smoother waterway transition through its most extreme bends which improves stream quality. (2) The offset configuration of the two pivot points create a condition where the reaction force of the water acting on the upper pivot point, if sufficient, will cause the nozzle to rotate upward about the lower pivot point. This produces a self-correcting increase in nozzle angle to protect against possibly dangerous unmanned use of the monitor at nozzle angles less than 35 degrees above horizontal. The hydraulic effect of the Safety System is active at approximately 350 GPM. The Safety System is patent pending.

Hydro-Loc Valve Position Control

The RAM XD shut off valve utilizes the Elkhart Brass Hydro-Loc mechanism to hold the valve in a throttled position if desired.

Fully Vaned Waterway

The waterway of the body has a full cast vane to improve water flow and discharge stream quality.

Inlet / Outlet Configuration

The RAM XD is manufactured standard with a 2.5" NH thread inlet and a 2.5" NH thread outlet. Special thread configurations can be addressed upon request.

NOZZLES

RAM XD Nozzles Options –

RAN

The RAN (Rapid Attack Nozzle) is a purpose built nozzle designed for use with the RAM XD. RAN is lightweight and utilizes very few components to deliver water in both straight stream and fog pattern. Significant to the stream quality of the RAN is its integral stream shaper. The RAN delivers 500 GPM at 75 psi and 400 GPM at 50 psi. The RAN is manufactured standard with 2.5" NH threaded swivel. Special thread configurations can be addressed upon request.



Selectable (3895)

Fixed (3896)

3896 (Fixed); 500 GPM (1893 LPM)

3895 (Selectable); 250/350/500 GPM (946/1325/1893 LPM)

181-A Smooth Bore; 1 3/8"

ST-197-A Stacked Tips; 1 1/2" – 1 1/4" – 1"

282-A Mini Stream Shaper; 2.5" x 2.5"



282-A Mini Stream Shaper

ST-197-A Stacked Tips

181-A 1-3/8" Smooth Bore

MONITOR ACCESSORY

Truck Mounting Bracket – 8296-MB

Elkhart Brass offers a light weight truck mounting bracket designed to hold the RAM XD in place during storage and truck transport. The bracket can be mounted in either the horizontal or vertical positions with strap orientation interchangeable between left and right latching.



OPERATING INSTRUCTIONS

The RAM XD is an easy to use device designed for single fire fighter deployment. However, any device capable of flowing 500 GPM can become very dangerous if not used properly. All personnel who use this device should be thoroughly familiar with its operation. The following outlines proper use of this device.

Deployment

- Retrieve the RAM XD from the mounting bracket or its storage area.
- Carry the RAM XD to the preferred location for deployment. Make sure to select a surface that is stable and level in proximity of a fixed object (tree, guard rail, post, etc) that can be used to secure the monitor.
- Extend each of the four legs making sure that the lock pin for each leg is securely in place.
- Place the RAM XD on the ground and position it so that it is in line with the target at which water is to be delivered. Take care to insure that all four carbide tipped ground spikes are securely in contact with the ground.
- Secure the RAM XD to a fixed object (tree, guard rail, post, etc) using the attached safety strap and take up any slack in the strap.
- If the RAM XD has not been utilized in a pre-connect condition, securely attach a hose line to the monitor at this point.



Important: All personal portable monitors must be secured to a stable fixed base to prevent uncontrolled movement during use – the monitor must be tied down.

Flowing Water

- Verify that there are no kinks in the hose line connected to the RAM XD. Also make sure that there is at least 20 feet of hose feeding into the RAM XD in direct line of the RAM XD's flow path for best quality of stream.
- Indicate to the pump operator to charge the line to the proper pressure / flow requirements.



Important: Never exceed 500 GPM and/or 150 PSI.

- Pull the lock pin on the valve control handle and slowly open the valve to its full open position.
- Keeping moderate weight on the RAM XD, move the nozzle to direct the discharge stream of water to the desired target.
- If it becomes necessary to move the monitor to a new location. Slowly close the valve control handle and verify that the lock pin is latched. The monitor can now be repositioned while the hose line is charged.
- If the RAM XD is repositioned, verify that the criteria outlined in the "Deployment section" have been satisfied.
- When use of the RAM XD is complete. Slowly close the valve control handle and verify that the lock pin is latched.

- Indicate to the pump operator to close the water feed to the hose line that is attached to the RAM XD. Any residual hose line pressure can be released by slowly opening and re-closing the valve control handle.



Important: Never straddle the hose line feeding the RAM XD. This can create a dangerous situation for the operator if there is any unwanted movement of the monitor, hose, etc. A knee or the hand opposite the hand being used to direct the stream of water can be conveniently placed on hose just behind the inlet connection for added monitor support.

Storage

- Remove the safety strap from the fixed object it had been secured to and place the strap back into the attached pouch.
- Fold the legs of the RAM XD by pulling outward on the lock pin cross lever to disengage it. The front legs are folded towards the back first and the rear legs are then folded forward.
- If the RAM XD is not to be stored in a pre-connect condition, disconnect the hose line from the monitor inlet.
- Return the RAM XD to its mounting bracket or storage area and secure for transportation.

MAINTENANCE INSTRUCTIONS

Recommended After Each Use

- Verify that the carbide tipped ground spike on each of the four legs is sharp and undamaged. If any tip has a flat larger than 1/16", replace the carbide tip. If any of the tips show signs of damage, replace the carbide tip ground spike before the next use.
- Verify that the lock pin mechanism for each leg is in good condition. Examine the lock pin end and the leg bracket slot that the lock pin connects for damage. If any damage is noticed, replace that specific leg assembly / bracket as needed. Examine the spring to insure it is operating properly. If any springs are not operating properly, replace that specific leg assembly. If necessary a light weight water repelling lubricant can be applied to the lock pin / spring mechanism in the legs.
- Inspect the safety strap for visible damage. The strap should be inspected for fraying and the D-Clip and Length Adjustment Ring should be inspected for physical damage. If any of the components are damaged they need to be replaced before the next use.
- Verify that the lock pin on the valve control handle is operating properly. If any damage or operational issue is detected, repair as necessary. If needed, a light weight water repelling lubricant can be applied to the valve control lock pin / spring mechanism.
- Operate the valve control handle from full closed to full open in order to insure the shut off ball is working properly and lubricated. The shut off ball can be observed from the inlet of the RAM XD.
- Visually inspect the RAM XD for any noticeable damage. Repair as needed

Recommended Every Six Months

- The valve ball should be inspected for physical damage and lubricated with a light grease.
- The RAM XD internal passage ways should be inspected for possible damage caused by foreign objects that have been carried by the water through the monitor. If damage affecting the integrity of the monitor is noticed, contact Elkhart Brass for assistance.

SYSTEM SPECIFICATIONS

8296 RAM XD Monitor

- Max Flow Rating 500 GPM (1893 LPM)
- Max Operating Pressure 150 PSI (10.3 BAR)
- Inlet Size 2.5" Female NHT Free Swivel
- Outlet Size 2.5" Male NHT
- Travel V: +14° to +51° (Manned)
V: +35° to +51° (Unmanned)
H: 20° in both directions (40°)
- Movement Manual
- Weight 19.25 Lbs. (22.45 Lbs. with RAN nozzle)
- Certifications CE

MONITOR AND NOZZLE HYDRAULIC DATA

Interpreting Flow Data

The following graphs offer the pressure losses for the monitor (and other devices) in terms of Total Static Pressure Drop. This Total Static Pressure Drop can be found by measuring the difference between the static inlet pressure and the static outlet pressure. The static pressure at either of these points can be found using a simple pressure gauge. An illustration of this method can be seen below.

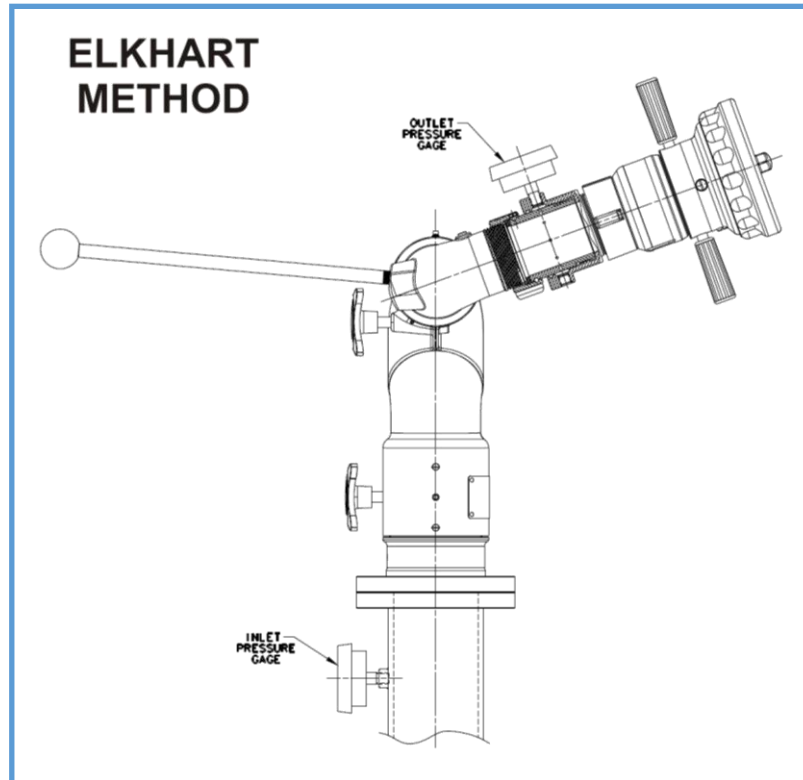

In mathematical terms, the Total Static Pressure Drop is the change in Velocity Pressure plus Friction Loss. The change in Velocity Pressure results from the change in velocity of water caused by the change in the cross section of a waterway. Friction Loss results from the drag and sidewall interference of the water through a device. A simple equation can be seen below.

$$\Delta P_S = H_F + \Delta P_V$$

ΔP_S = Total Static Pressure Drop
 H_F = Friction Loss
 ΔP_V = Velocity Pressure Loss

In the firefighting industry, the terms Total Static Pressure Drop and Friction Loss tend to be used interchangeably. However, these are significantly different measurements. This misconception could ultimately lead to lower than anticipated performance from equipment. **When designing a system and determining performance, Total Static Pressure Drop is the value that should always be used.** The Friction Loss curve is also supplied in order to make a comparison with competitor products that may only supply Friction Loss curves. If there are any further questions regarding this matter, please contact Elkhart Brass.

8296 RAM XD Losses 2.5" Inlet & 2.5" Outlet

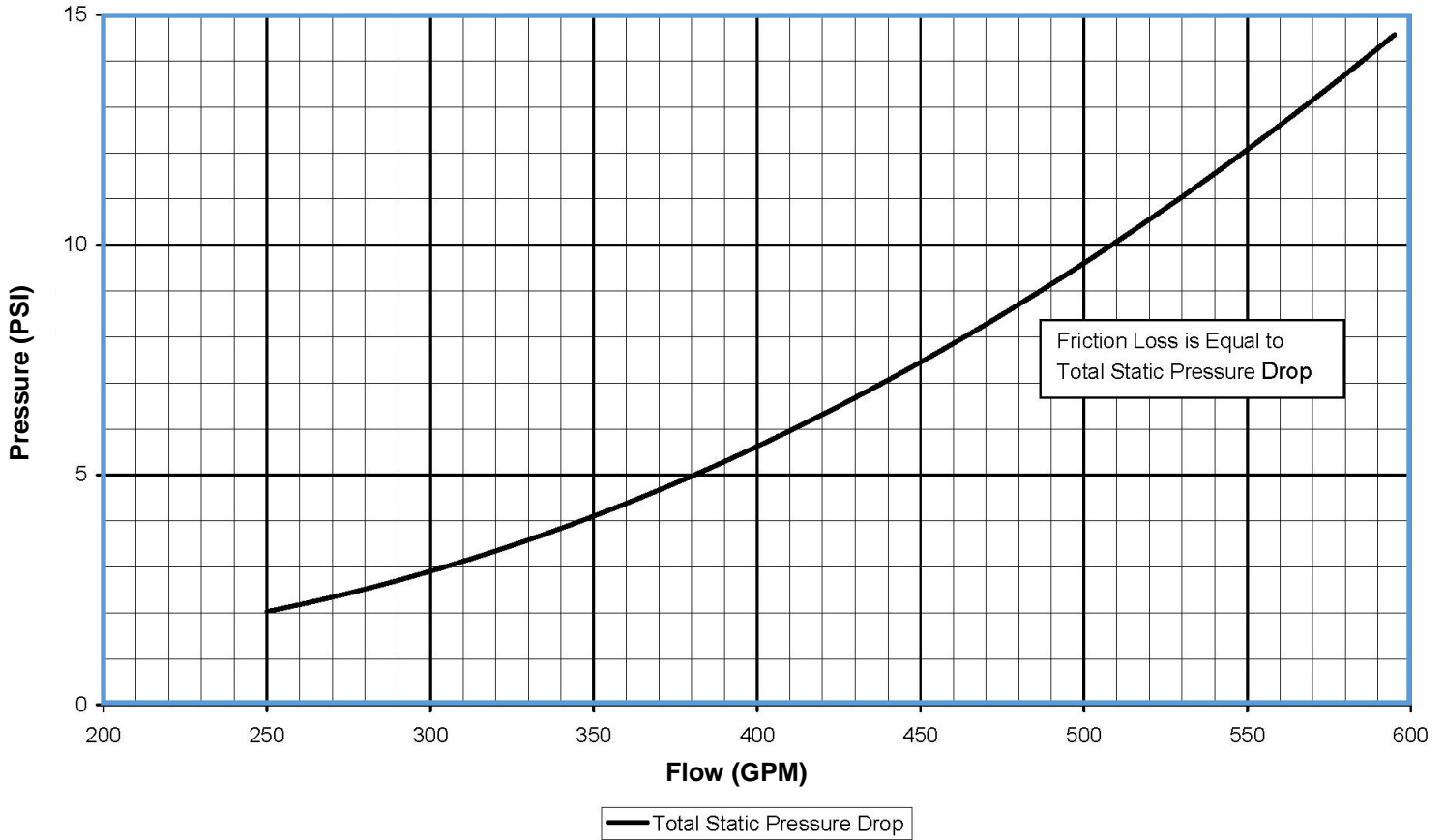

CATALOG NO.	INLET SIZE	STREAM SETTING	NOZZLE DISCHARGE U.S. GPM							EFFECTIVE REACH in FEET						
			NOZZLE PRESSURE PSI							NOZZLE PRESSURE PSI						
			40	50	60	70	80	90	100	40	50	60	70	80	90	100
3896 RAN	2.5	SS								135	159	162	172	181	188	194
		NARROW FOG	358	400	443	477	509	540	570	92	101	109	117	125	133	140
		WIDE FOG								48	52	56	60	63	67	71

MOUNTING TEMPLATES

NOTE: Mounting Bracket is not to scale and should be used as a guide

8296 Mounting Bracket

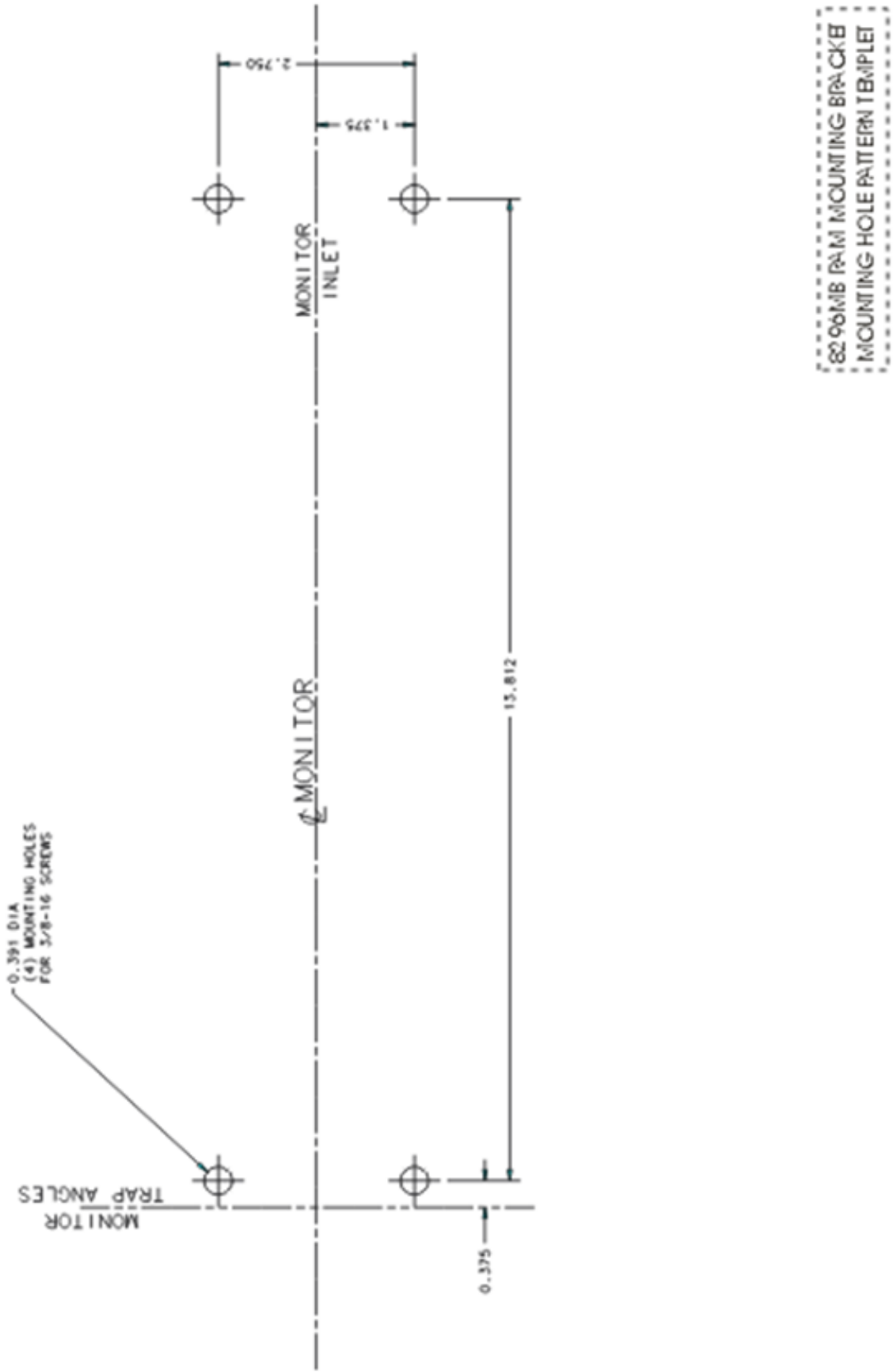



ELKHART BRASS
PHYSICAL: 1302 WEST BEARDSLEY AVE • ELKHART, IN 46514
MAILING: P.O. BOX 1127 • ELKHART, IN 46515
PHONE: 1-574-295-8330 • 1-800-346-0250
FAX: 1-574-293-9914
WWW.ELKHARTBRASS.COM
eb.info@safefleet.net

© ELKHART BRASS MFG. CO., INC. 2017

8296 RAM XD MONITOR
OPERATION AND MAINTENANCE INSTRUCTIONS
98293050 REV. A
